

## TS5A23159 1-Ω 2-Channel SPDT Analog Switch 5-V / 3.3-V 2-Channel 2:1 Multiplexer / Demultiplexer

### 1 Features

- Isolation in Power-Down Mode,  $V_{CC} = 0$
- Specified Break-Before-Make Switching
- Low ON-State Resistance (1 Ω)
- Control Inputs are 5.5-V Tolerant
- Low Charge Injection
- Excellent ON-State Resistance Matching
- Low Total Harmonic Distortion (THD)
- Supports Analog and Digital Signals
- 1.65-V to 5.5-V Single-Supply Operation
- Latch-Up Performance Exceeds 100 mA Per JESD 78, Class II
- ESD Performance Tested Per JESD 22
  - 2000-V Human Body Model (A114-B, Class II)
  - 1000-V Charged-Device Model (C101)

### 2 Applications

- Cell Phones
- PDAs
- Portable Instrumentation
- Audio and Video Signal Routing
- Low-Voltage Data-Acquisition Systems
- Communication Circuits
- Modems
- Hard Drives
- Computer Peripherals
- Wireless Terminals and Peripherals

### 3 Description

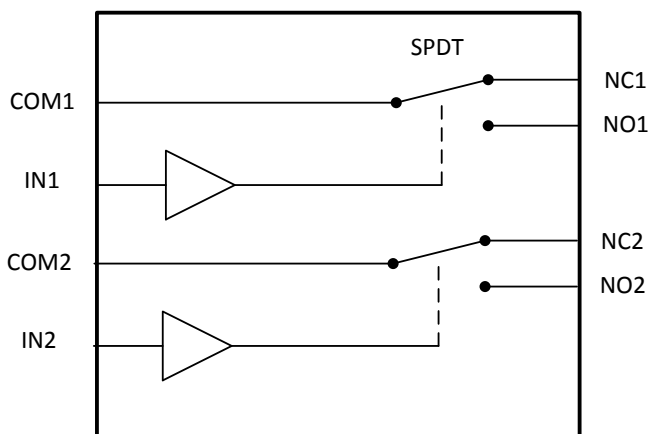
The TS5A23159 is a bidirectional 2-channel single-pole double-throw (SPDT) switch that is designed to operate from 1.65 V to 5.5 V. The device offers low ON-state resistance and excellent ON-state resistance matching with the break-before-make feature which prevents signal distortion during the transferring of a signal from one channel to another. The device has an excellent total harmonic distortion (THD) performance and consumes very low power. These features make this device suitable for a wide variety of portable applications including cell phones, audio devices, and instrumentation.

#### Device Information<sup>(1)</sup>

PART NUMBER	PACKAGE	BODY SIZE (NOM)
TS5A23159	VSSOP (10)	3.00 mm × 3.00 mm
	UQFN (10)	1.50 mm × 2.00 mm

(1) For all available packages, see the orderable addendum at the end of the data sheet.

#### Simplified Schematic



## Table of Contents

<b>1 Features</b> ..... 1 <b>2 Applications</b> ..... 1 <b>3 Description</b> ..... 1 <b>4 Revision History</b> ..... 2 <b>5 Pin Configuration and Functions</b> ..... 3 <b>6 Specifications</b> ..... 3 6.1 Absolute Maximum Ratings ..... 3 6.2 ESD Ratings ..... 4 6.3 Recommended Operating Conditions ..... 4 6.4 Thermal Information ..... 4 6.5 Electrical Characteristics for 5-V Supply ..... 5 6.6 Electrical Characteristics for 3.3-V Supply ..... 7 6.7 Electrical Characteristics for 2.5-V Supply ..... 9 6.8 Electrical Characteristics for 1.8-V Supply ..... 11 6.9 Typical Characteristics ..... 13 <b>7 Parameter Measurement Information</b> ..... 16 <b>8 Detailed Description</b> ..... 21	8.1 Overview ..... 21 8.2 Functional Block Diagram ..... 21 8.3 Feature Description ..... 21 8.4 Device Functional Modes ..... 21 <b>9 Application and Implementation</b> ..... 22 9.1 Application Information ..... 22 9.2 Typical Application ..... 22 <b>10 Power Supply Recommendations</b> ..... 23 <b>11 Layout</b> ..... 24 11.1 Layout Guidelines ..... 24 11.2 Layout Example ..... 24 <b>12 Device and Documentation Support</b> ..... 25 12.1 Trademarks ..... 25 12.2 Electrostatic Discharge Caution ..... 25 12.3 Glossary ..... 25 <b>13 Mechanical, Packaging, and Orderable Information</b> ..... 25
--	--

## 4 Revision History

NOTE: Page numbers for previous revisions may differ from page numbers in the current version.

Changes from Revision G (August 2013) to Revision H	Page
<ul style="list-style-type: none"> <li>• Added <i>ESD Ratings</i> table, <i>Recommended Operating Conditions</i> table, <i>Thermal Information</i> table, <i>Feature Description</i> section, <i>Device Functional Modes</i>, <i>Application and Implementation</i> section, <i>Power Supply Recommendations</i> section, <i>Layout</i> section, <i>Device and Documentation Support</i> section, and <i>Mechanical, Packaging, and Orderable Information</i> section ..... 1</li> </ul>	1

Changes from Revision F (September 2010) to Revision G	Page
<ul style="list-style-type: none"> <li>• Aligned package description throughout datasheet ..... 1</li> <li>• Removed <i>Ordering Information</i> table. .... 1</li> </ul>	1

## 5 Pin Configuration and Functions



### Pin Functions

PIN		I/O	DESCRIPTION
NO.	NAME		
1	IN1	I	Digital control to connect COM to NO or NC
2	NO1	I/O	Normally open
3	GND	—	Ground
4	NO2	I/O	Normally open
5	IN2	I	Digital control to connect COM to NO or NC
6	COM2	I/O	Common
7	NC2	I/O	Normally closed
8	VCC	—	Power supply
9	NC1	I/O	Normally closed
10	COM1	I/O	Common

## 6 Specifications

### 6.1 Absolute Maximum Ratings

over operating free-air temperature range (unless otherwise noted)<sup>(1)(2)</sup>

		MIN	MAX	UNIT
$V_{CC}$	Supply voltage <sup>(3)</sup>	-0.5	6.5	V
$V_{NC}$ $V_{NO}$ $V_{COM}$	Analog voltage <sup>(3) (4) (5)</sup>	-0.5	$V_{CC} + 0.5$	V
$I_K$	Analog port diode current	$V_{NC}, V_{NO}, V_{COM} < 0$		mA
$I_{NC}$ $I_{NO}$ $I_{COM}$	On-state switch current	-200	200	mA
	On-state peak switch current <sup>(6)</sup>	-400	400	
$V_{IN}$	Digital input voltage <sup>(3) (4)</sup>	-0.5	6.5	V
$I_{IK}$	Digital input clamp current	$V_I < 0$		mA
$I_{CC}$	Continuous current through $V_{CC}$		100	mA
$I_{GND}$	Continuous current through GND	-100	100	mA
$T_{stg}$	Storage temperature	-65	150	°C

- Stresses beyond those listed under *Absolute Maximum Ratings* may cause permanent damage to the device. These are stress ratings only, which do not imply functional operation of the device at these or any other conditions beyond those indicated under *Recommended Operating Conditions*. Exposure to absolute-maximum-rated conditions for extended periods may affect device reliability.
- The algebraic convention, whereby the most negative value is a minimum and the most positive value is a maximum
- All voltages are with respect to ground, unless otherwise specified.
- The input and output voltage ratings may be exceeded if the input and output clamp-current ratings are observed.
- This value is limited to 5.5 V maximum.
- Pulse at 1-ms duration < 10% duty cycle

## 6.2 ESD Ratings

		VALUE	UNIT
$V_{(ESD)}$ Electrostatic discharge	Human-body model (HBM), per ANSI/ESDA/JEDEC JS-001 <sup>(1)</sup>	±2000	V
	Charged-device model (CDM), per JEDEC specification JESD22-C101 <sup>(2)</sup>	±1000	

(1) JEDEC document JEP155 states that 500-V HBM allows safe manufacturing with a standard ESD control process.

(2) JEDEC document JEP157 states that 250-V CDM allows safe manufacturing with a standard ESD control process.

## 6.3 Recommended Operating Conditions

over operating free-air temperature range (unless otherwise noted)

		MIN	MAX	UNIT
$V_{CC}$ Supply LC Voltage		0	5.5	V
$V_{NC}$ Analog voltage		0	$V_{CC}$	
$V_{NO}$ $V_{COM}$				
$V_{IN}$ Digital input voltage range		0	$V_{CC}$	

## 6.4 Thermal Information

THERMAL METRIC <sup>(1)</sup>	TS5A23159		UNIT
	DGS (VSSOP)	RSE (UQFN)	
	10 PINS	10 PINS	
$R_{\theta JA}$ Junction-to-ambient thermal resistance	203.9	180.8	°C/W
$R_{\theta JC(top)}$ Junction-to-case (top) thermal resistance	88.3	117.8	
$R_{\theta JB}$ Junction-to-board thermal resistance	123.9	98.6	
$\psi_{JT}$ Junction-to-top characterization parameter	2.1	6.8	
$\psi_{JB}$ Junction-to-board characterization parameter	122.5	98.4	
$R_{\theta JC(bot)}$ Junction-to-case (bottom) thermal resistance	—	—	

(1) For more information about traditional and new thermal metrics, see the *IC Package Thermal Metrics* application report, [SPRA953](#).

## 6.5 Electrical Characteristics for 5-V Supply

 $V_{CC} = 4.5\text{ V to }5.5\text{ V}$ ,  $T_A = -40^\circ\text{C to }85^\circ\text{C}$  (unless otherwise noted)<sup>(1)</sup>

PARAMETER		TEST CONDITIONS		$T_A$	$V_{CC}$	MIN	TYP	MAX	UNIT
<b>ANALOG SWITCH</b>									
$V_{COM}$ $V_{NO}$ $V_{NC}$	Analog signal range					0		$V_{CC}$	V
$R_{peak}$	Peak ON resistance	$0 \leq (V_{NO} \text{ or } V_{NC}) \leq V_{CC}$ , $I_{COM} = -100\text{ mA}$ ,	Switch ON, See <a href="#">Figure 14</a>	25°C Full	4.5 V		0.8 1.1	1.5	$\Omega$
$R_{on}$	ON-state resistance	$V_{NO} \text{ or } V_{NC} = 2.5\text{ V}$ , $I_{COM} = -100\text{ mA}$ ,	Switch ON, See <a href="#">Figure 14</a>	25°C Full	4.5 V		0.7 0.9	1.1	$\Omega$
$\Delta R_{on}$	ON-state resistance match between channels	$V_{NO} \text{ or } V_{NC} = 2.5\text{ V}$ , $I_{COM} = -100\text{ mA}$ ,	Switch ON, See <a href="#">Figure 14</a>	25°C Full	4.5 V		0.05 0.1	0.1	$\Omega$
$R_{on(Flat)}$	ON-state resistance flatness	$0 \leq (V_{NO} \text{ or } V_{NC}) \leq V_{CC}$ , $I_{COM} = -100\text{ mA}$ ,	Switch ON, See <a href="#">Figure 14</a>	25°C	4.5 V		0.15		$\Omega$
				Full			0.1 0.25	0.25	
$I_{NO(OFF)}$ , $I_{NC(OFF)}$	NC, NO OFF leakage current	$V_{NC} \text{ or } V_{NO} = 1\text{ V}$ , $V_{COM} = 1\text{ V to }4.5\text{ V}$ , or $V_{NC} \text{ or } V_{NO} = 4.5\text{ V}$ , $V_{COM} = 1\text{ V to }4.5\text{ V}$ ,	Switch OFF, See <a href="#">Figure 15</a>	25°C	5.5 V		-20 2	20	nA
				Full			-100	100	
$I_{NC(PWROFF)}$ , $I_{NO(PWROFF)}$		$V_{NC} \text{ or } V_{NO} = 0\text{ to }5.5\text{ V}$ , $V_{COM} = 5.5\text{ V to }0$ ,	Switch OFF, See <a href="#">Figure 15</a>	25°C	0 V		-1 0.2	1	$\mu\text{A}$
				Full			-20	20	
$I_{NO(ON)}$ , $I_{NC(ON)}$	NC, NO ON leakage current	$V_{NC} \text{ or } V_{NO} = 1\text{ V}$ , $V_{COM} = \text{Open}$ , or $V_{NC} \text{ or } V_{NO} = 4.5\text{ V}$ , $V_{COM} = \text{Open}$ ,	Switch ON, See <a href="#">Figure 16</a>	25°C	5.5 V		-20 2	20	nA
				Full			-100	100	
$I_{COM(PWROFF)}$	COM OFF leakage current	$V_{NC} \text{ or } V_{NO} = 0\text{ to }5.5\text{ V}$ , $V_{COM} = 5.5\text{ V to }0$ ,	Switch OFF, See <a href="#">Figure 15</a>	25°C	0 V		-1 0.1	1	$\mu\text{A}$
				Full			-20	20	
$I_{COM(ON)}$	COM ON leakage current	$V_{NC} \text{ or } V_{NO} = \text{Open}$ , $V_{COM} = 1\text{ V}$ , or $V_{NC} \text{ or } V_{NO} = \text{Open}$ , $V_{COM} = 4.5\text{ V}$ ,	Switch ON, See <a href="#">Figure 16</a>	25°C	5.5 V		-20 2	20	nA
				Full			-100	100	
<b>DIGITAL CONTROL INPUTS (IN1, IN2)<sup>(2)</sup></b>									
$V_{IH}$	Input logic high			Full		2.4		5.5	V
$V_{IL}$	Input logic low			Full		0		0.8	V
$I_{IH}$ , $I_{IL}$	Input leakage current	$V_{IN} = 5.5\text{ V or }0$		25°C	5.5 V			2	nA
				Full			-100	100	
<b>DYNAMIC</b>									
$t_{ON}$	Turnon time	$V_{COM} = V_{CC}$ , $R_L = 50\ \Omega$ ,	$C_L = 35\text{ pF}$ , See <a href="#">Figure 18</a>	25°C	5 V	1	8	13	ns
				Full	4.5 V to 5.5 V	1		16.5	
$t_{OFF}$	Turnoff time	$V_{COM} = V_{CC}$ , $R_L = 50\ \Omega$ ,	$C_L = 35\text{ pF}$ , See <a href="#">Figure 18</a>	25°C	5 V	1	5	8	ns
				Full	4.5 V to 5.5 V	1		8	

(1) The algebraic convention, whereby the most negative value is a minimum and the most positive value is a maximum

(2) All unused digital inputs of the device must be held at  $V_{CC}$  or GND to ensure proper device operation. Refer to the TI application report, *Implications of Slow or Floating CMOS Inputs*, [SCBA004](#).

**Electrical Characteristics for 5-V Supply (continued)**
 $V_{CC} = 4.5 \text{ V to } 5.5 \text{ V}$ ,  $T_A = -40^\circ\text{C to } 85^\circ\text{C}$  (unless otherwise noted)<sup>(1)</sup>

PARAMETER		TEST CONDITIONS		$T_A$	$V_{CC}$	MIN	TYP	MAX	UNIT
$t_{BBM}$	Break-before-make time	$V_{NC} = V_{NO} = V_{CC}$ , $R_L = 50 \Omega$ ,	$C_L = 35 \text{ pF}$ , See <a href="#">Figure 19</a>	25°C	5 V	1	5.5	13	ns
				Full	4.5 V to 5.5 V	1		14	
$Q_C$	Charge injection	$V_{GEN} = 0$ , $R_{GEN} = 0$ ,	$C_L = 1 \text{ nF}$ , See <a href="#">Figure 23</a>	25°C	5 V		-7		pC
$C_{NC(OFF)}$ , $C_{NO(OFF)}$	NC, NO OFF capacitance	$V_{NC}$ or $V_{NO} = V_{CC}$ or GND, Switch OFF,	See <a href="#">Figure 17</a>	25°C	5 V		18		pF
$C_{NC(ON)}$ , $C_{NO(ON)}$	NC, NO ON capacitance	$V_{NC}$ or $V_{NO} = V_{CC}$ or GND, Switch ON,	See <a href="#">Figure 17</a>	25°C	5 V		55		pF
$C_{COM(ON)}$	COM ON capacitance	$V_{COM} = V_{CC}$ or GND, Switch ON,	See <a href="#">Figure 17</a>	25°C	5 V		54.5		pF
$C_I$	Digital input capacitance	$V_{IN} = V_{CC}$ or GND,	See <a href="#">Figure 17</a>	25°C	5 V		2		pF
BW	Bandwidth	$R_L = 50 \Omega$ , Switch ON,	See <a href="#">Figure 20</a>	25°C	5 V		100		MHz
$O_{ISO}$	OFF isolation	$R_L = 50 \Omega$ , $f = 1 \text{ MHz}$ ,	Switch OFF, See <a href="#">Figure 21</a>	25°C	5 V		-64		dB
$X_{TALK}$	Crosstalk	$R_L = 50 \Omega$ , $f = 1 \text{ MHz}$ ,	Switch ON, See <a href="#">Figure 22</a>	25°C	5 V		-64		dB
THD	Total harmonic distortion	$R_L = 600 \Omega$ , $C_L = 50 \text{ pF}$ ,	$f = 20 \text{ Hz to } 20 \text{ kHz}$ , See <a href="#">Figure 24</a>	25°C	5 V		0.004%		
<b>SUPPLY</b>									
$I_{CC}$	Positive supply current	$V_{IN} = V_{CC}$ or GND,	Switch ON or OFF	25°C	5.5 V		10	50	nA
				Full			750		

## 6.6 Electrical Characteristics for 3.3-V Supply

 $V_{CC} = 3\text{ V to }3.6\text{ V}$ ,  $T_A = -40^\circ\text{C to }85^\circ\text{C}$  (unless otherwise noted)<sup>(1)</sup>

PARAMETER		TEST CONDITIONS		$T_A$	$V_{CC}$	MIN	TYP	MAX	UNIT	
<b>ANALOG SWITCH</b>										
$V_{COM}$ , $V_{NO}$ , $V_{NC}$	Analog signal range					0		$V_{CC}$	V	
$R_{peak}$	Peak ON resistance	$0 \leq (V_{NO} \text{ or } V_{NC}) \leq V_{CC}$ , $I_{COM} = -100\text{ mA}$ ,	Switch ON, See <a href="#">Figure 14</a>	25°C	3 V		1.3	1.6	$\Omega$	
				Full			2			
$R_{on}$	ON-state resistance	$V_{NO} \text{ or } V_{NC} = 2\text{ V}$ , $I_{COM} = -100\text{ mA}$ ,	Switch ON, See <a href="#">Figure 14</a>	25°C	3 V		1.2	1.5	$\Omega$	
				Full			1.7			
$\Delta R_{on}$	ON-state resistance match between channels	$V_{NO} \text{ or } V_{NC} = 2\text{ V}$ , 0.8 V, $I_{COM} = -100\text{ mA}$ ,	Switch ON, See <a href="#">Figure 14</a>	25°C	3 V		0.1	0.15	$\Omega$	
				Full			0.2			
$R_{on(Flat)}$	ON-state resistance flatness	$0 \leq (V_{NO} \text{ or } V_{NC}) \leq V_{CC}$ , $I_{COM} = -100\text{ mA}$ ,	Switch ON, See <a href="#">Figure 14</a>	25°C	3 V		0.15		$\Omega$	
				25°C						
				Full						
$I_{NO(OFF)}$ , $I_{NC(OFF)}$	NC, NO OFF leakage current	$V_{NC} \text{ or } V_{NO} = 1\text{ V}$ , $V_{COM} = 1\text{ V to }3\text{ V}$ , or $V_{NC} \text{ or } V_{NO} = 3\text{ V}$ , $V_{COM} = 1\text{ V to }3\text{ V}$ ,	Switch OFF, See <a href="#">Figure 15</a>	25°C	3.6 V		-20	2	20	nA
				Full			-50	50		
$I_{NC(PWROFF)}$ , $I_{NO(PWROFF)}$		$V_{NC} \text{ or } V_{NO} = 0\text{ to }3.6\text{ V}$ , $V_{COM} = 3.6\text{ V to }0$ ,	Switch OFF, See <a href="#">Figure 15</a>	25°C	0 V		-1	0.2	1	$\mu\text{A}$
				Full			-15	15		
$I_{NO(ON)}$ , $I_{NC(ON)}$	NC, NO ON leakage current	$V_{NC} \text{ or } V_{NO} = 1\text{ V}$ , $V_{COM} = \text{Open}$ , or $V_{NC} \text{ or } V_{NO} = 3\text{ V}$ , $V_{COM} = \text{Open}$ ,	Switch ON, See <a href="#">Figure 16</a>	25°C	3.6 V		-10	2	10	nA
				Full			-20	20		
$I_{COM(PWROFF)}$	COM OFF leakage current	$V_{NC} \text{ or } V_{NO} = 3.6\text{ V to }0$ , $V_{COM} = 0\text{ to }3.6\text{ V}$ ,	Switch OFF, See <a href="#">Figure 15</a>	25°C	0 V		-1	0.2	1	$\mu\text{A}$
				Full			-15	15		
$I_{COM(ON)}$	COM ON leakage current	$V_{NC} \text{ or } V_{NO} = \text{Open}$ , $V_{COM} = 1\text{ V}$ , or $V_{NC} \text{ or } V_{NO} = \text{Open}$ , $V_{COM} = 3\text{ V}$ ,	Switch ON, See <a href="#">Figure 16</a>	25°C	3.6 V		-10	2	10	nA
				Full			-20	20		
<b>DIGITAL CONTROL INPUTS (IN1, IN2)<sup>(2)</sup></b>										
$V_{IH}$	Input logic high			Full		2		5.5	V	
$V_{IL}$	Input logic low			Full		0		0.8	V	
$I_{IH}$ , $I_{IL}$	Input leakage current	$V_{IN} = 5.5\text{ V or }0$		25°C	3.6 V		-2	2	nA	
				Full			-20	20		
<b>DYNAMIC</b>										
$t_{ON}$	Turnon time	$V_{COM} = V_{CC}$ , $R_L = 50\ \Omega$ ,	$C_L = 35\text{ pF}$ , See <a href="#">Figure 18</a>	25°C	3.3 V	5	11	19	ns	
				Full	3 V to 3.6 V	3		22		
$t_{OFF}$	Turnoff time	$V_{COM} = V_{CC}$ , $R_L = 50\ \Omega$ ,	$C_L = 35\text{ pF}$ , See <a href="#">Figure 18</a>	25°C	3.3 V	1	5	9	ns	
				Full	3 V to 3.6 V	1		9		
$t_{BBM}$	Break-before-make time	$V_{NC} = V_{NO} = V_{CC}$ , $R_L = 50\ \Omega$ ,	$C_L = 35\text{ pF}$ , See <a href="#">Figure 19</a>	25°C	3.3 V	1	7	17	ns	
				Full	3 V to 3.6 V	1		20		

(1) The algebraic convention, whereby the most negative value is a minimum and the most positive value is a maximum

(2) All unused digital inputs of the device must be held at  $V_{CC}$  or GND to ensure proper device operation. Refer to the TI application report, *Implications of Slow or Floating CMOS Inputs*, [SCBA004](#).

**Electrical Characteristics for 3.3-V Supply (continued)**
 $V_{CC} = 3\text{ V to }3.6\text{ V}$ ,  $T_A = -40^\circ\text{C to }85^\circ\text{C}$  (unless otherwise noted)<sup>(1)</sup>

PARAMETER		TEST CONDITIONS		$T_A$	$V_{CC}$	MIN	TYP	MAX	UNIT
$Q_C$	Charge injection	$V_{GEN} = 0$ , $R_{GEN} = 0$ ,	$C_L = 1\text{ nF}$ , See <a href="#">Figure 23</a>	25°C	3.3 V		-4		pC
$C_{NC(OFF)}$ , $C_{NO(OFF)}$	NC, NO OFF capacitance	$V_{NC}$ or $V_{NO} = V_{CC}$ or GND, Switch OFF,	See <a href="#">Figure 17</a>	25°C	3.3 V		18		pF
$C_{NC(ON)}$ , $C_{NO(ON)}$	NC, NO ON capacitance	$V_{NC}$ or $V_{NO} = V_{CC}$ or GND, Switch ON,	See <a href="#">Figure 17</a>	25°C	3.3 V		56		pF
$C_{COM(ON)}$	COM ON capacitance	$V_{COM} = V_{CC}$ or GND, Switch ON,	See <a href="#">Figure 17</a>	25°C	3.3 V		56		pF
$C_I$	Digital input capacitance	$V_{IN} = V_{CC}$ or GND,	See <a href="#">Figure 17</a>	25°C	3.3 V		2		pF
BW	Bandwidth	$R_L = 50\ \Omega$ , Switch ON,	See <a href="#">Figure 20</a>	25°C	3.3 V		100		MHz
$O_{ISO}$	OFF isolation	$R_L = 50\ \Omega$ , $f = 1\text{ MHz}$ ,	Switch OFF, See <a href="#">Figure 21</a>	25°C	3.3 V		-64		dB
$X_{TALK}$	Crosstalk	$R_L = 50\ \Omega$ , $f = 1\text{ MHz}$ ,	Switch ON, See <a href="#">Figure 22</a>	25°C	3.3 V		-64		dB
THD	Total harmonic distortion	$R_L = 600\ \Omega$ , $C_L = 50\text{ pF}$ ,	$f = 20\text{ Hz to }20\text{ kHz}$ , See <a href="#">Figure 24</a>	25°C	3.3 V		0.01%		
<b>SUPPLY</b>									
$I_{CC}$	Positive supply current	$V_{IN} = V_{CC}$ or GND,	Switch ON or OFF	25°C	3.6 V				25
				Full					150
									nA

## 6.7 Electrical Characteristics for 2.5-V Supply<sup>(1)</sup>

 $V_{CC} = 2.3 \text{ V to } 2.7 \text{ V}$ ,  $T_A = -40^\circ\text{C to } 85^\circ\text{C}$  (unless otherwise noted)

PARAMETER		TEST CONDITIONS		$T_A$	$V_{CC}$	MIN	TYP	MAX	UNIT
<b>ANALOG SWITCH</b>									
$V_{COM}$ , $V_{NO}$ , $V_{NC}$	Analog signal range					0		$V_{CC}$	V
$R_{peak}$	Peak ON resistance	$0 \leq (V_{NO} \text{ or } V_{NC}) \leq V_{CC}$ , $I_{COM} = -8 \text{ mA}$ ,	Switch ON, See <a href="#">Figure 14</a>	25°C Full	2.3 V		1.8	2.5 2.7	$\Omega$
$R_{on}$	ON-state resistance	$V_{NO} \text{ or } V_{NC} = 1.8 \text{ V}$ , $I_{COM} = -8 \text{ mA}$ ,	Switch ON, See <a href="#">Figure 14</a>	25°C Full	2.3 V		1.5	2 2.4	$\Omega$
$\Delta R_{on}$	ON-state resistance match between channels	$V_{NO} \text{ or } V_{NC} = 1.8 \text{ V}$ , 0.8 V, $I_{COM} = -8 \text{ mA}$ ,	Switch ON, See <a href="#">Figure 14</a>	25°C Full	2.3 V		0.15	0.2 0.2	$\Omega$
$R_{on(Flat)}$	ON-state resistance flatness	$0 \leq (V_{NO} \text{ or } V_{NC}) \leq V_{CC}$ , $I_{COM} = -8 \text{ mA}$ ,	Switch ON, See <a href="#">Figure 14</a>	25°C 25°C Full	2.3 V		0.6	0.6 1 1	$\Omega$
$I_{NO(OFF)}$ , $I_{NC(OFF)}$	NC, NO OFF leakage current	$V_{NC} \text{ or } V_{NO} = 0.5 \text{ V}$ , $V_{COM} = 0.5 \text{ V to } 2.3 \text{ V}$ , or $V_{NC} \text{ or } V_{NO} = 2.2 \text{ V}$ , $V_{COM} = 0.5 \text{ V to } 2.3 \text{ V}$ ,	Switch OFF, See <a href="#">Figure 15</a>	25°C	2.3 V	-20	2	20	nA
Full				-50			50		
$I_{NC(PWROFF)}$ , $I_{NO(PWROFF)}$		$V_{NC} \text{ or } V_{NO} = 0 \text{ to } 2.7 \text{ V}$ , $V_{COM} = 2.7 \text{ V to } 0$ ,	Switch OFF, See <a href="#">Figure 15</a>	25°C	0 V	-1	0.1	1.0	$\mu\text{A}$
Full				-10			10		
$I_{NO(ON)}$ , $I_{NC(ON)}$	NC, NO ON leakage current	$V_{NC} \text{ or } V_{NO} = 0.5 \text{ V}$ , $V_{COM} = \text{Open}$ , or $V_{NC} \text{ or } V_{NO} = 2.2 \text{ V}$ , $V_{COM} = \text{Open}$ ,	Switch ON, See <a href="#">Figure 16</a>	25°C	2.7 V	-10	2	10	nA
Full				-20			20		
$I_{COM(PWROFF)}$	COM OFF leakage current	$V_{NC} \text{ or } V_{NO} = 2.7 \text{ V to } 0$ , $V_{COM} = 0 \text{ to } 2.7 \text{ V}$ ,	Switch OFF, See <a href="#">Figure 15</a>	25°C Full	0 V	-1	0.1	1 10	$\mu\text{A}$
$I_{COM(ON)}$	COM ON leakage current	$V_{NC} \text{ or } V_{NO} = \text{Open}$ , $V_{COM} = 0.5 \text{ V}$ , or $V_{NC} \text{ or } V_{NO} = \text{Open}$ , $V_{COM} = 2.2 \text{ V}$ ,	Switch ON, See <a href="#">Figure 16</a>	25°C Full	2.7 V	-10	2	10 20	nA
<b>DIGITAL CONTROL INPUTS (IN1, IN2)<sup>(2)</sup></b>									
$V_{IH}$	Input logic high			Full		1.8		5.5	V
$V_{IL}$	Input logic low			Full		0		0.6	V
$I_{IH}$ , $I_{IL}$	Input leakage current	$V_{IN} = 5.5 \text{ V or } 0$		25°C	2.7 V	-2		2	nA
Full				-20			20		
<b>DYNAMIC</b>									
$t_{ON}$	Turnon time	$V_{COM} = V_{CC}$ , $R_L = 50 \Omega$ ,	$C_L = 35 \text{ pF}$ , See <a href="#">Figure 18</a>	25°C	2.5 V	5	15	28	ns
Full				2.3 V to 2.7 V	5		32		
$t_{OFF}$	Turnoff time	$V_{COM} = V_{CC}$ , $R_L = 50 \Omega$ ,	$C_L = 35 \text{ pF}$ , See <a href="#">Figure 18</a>	25°C	2.5 V	2	6	9	ns
Full				2.3 V to 2.7 V	2		10		
$t_{BBM}$	Break-before-make time	$V_{NC} = V_{NO} = V_{CC}$ , $R_L = 50 \Omega$ ,	$C_L = 35 \text{ pF}$ , See <a href="#">Figure 19</a>	25°C	2.5 V	1	10	27	ns
Full				2.3 V to 2.7 V	1		30		

(1) The algebraic convention, whereby the most negative value is a minimum and the most positive value is a maximum

(2) All unused digital inputs of the device must be held at  $V_{CC}$  or GND to ensure proper device operation. Refer to the TI application report, *Implications of Slow or Floating CMOS Inputs*, [SCBA004](#).

**Electrical Characteristics for 2.5-V Supply<sup>(1)</sup> (continued)**
 $V_{CC} = 2.3 \text{ V to } 2.7 \text{ V}$ ,  $T_A = -40^\circ\text{C to } 85^\circ\text{C}$  (unless otherwise noted)

PARAMETER		TEST CONDITIONS		$T_A$	$V_{CC}$	MIN	TYP	MAX	UNIT
$Q_C$	Charge injection	$V_{GEN} = 0$ , $R_{GEN} = 0$ ,	$C_L = 1 \text{ nF}$ , See <a href="#">Figure 23</a>	25°C	2.5 V		-3		pC
$C_{NC(OFF)}$ , $C_{NO(OFF)}$	NC, NO OFF capacitance	$V_{NC}$ or $V_{NO} = V_{CC}$ or GND, Switch OFF,	See <a href="#">Figure 17</a>	25°C	2.5 V		18.5		pF
$C_{NC(ON)}$ , $C_{NO(ON)}$	NC, NO ON capacitance	$V_{NC}$ or $V_{NO} = V_{CC}$ or GND, Switch ON,	See <a href="#">Figure 17</a>	25°C	2.5 V		56.5		pF
$C_{COM(ON)}$	COM ON capacitance	$V_{COM} = V_{CC}$ or GND, Switch ON,	See <a href="#">Figure 17</a>	25°C	2.5 V		56.5		pF
$C_I$	Digital input capacitance	$V_{IN} = V_{CC}$ or GND,	See <a href="#">Figure 17</a>	25°C	2.5 V		2		pF
BW	Bandwidth	$R_L = 50 \Omega$ , Switch ON,	See <a href="#">Figure 20</a>	25°C	2.5 V		100		MHz
$O_{ISO}$	OFF isolation	$R_L = 50 \Omega$ , $f = 1 \text{ MHz}$ ,	Switch OFF, See <a href="#">Figure 21</a>	25°C	2.5 V		-64		dB
$X_{TALK}$	Crosstalk	$R_L = 50 \Omega$ , $f = 1 \text{ MHz}$ ,	Switch ON, See <a href="#">Figure 22</a>	25°C	2.5 V		-64		dB
THD	Total harmonic distortion	$R_L = 600 \Omega$ , $C_L = 50 \text{ pF}$ ,	$f = 20 \text{ Hz to } 20 \text{ kHz}$ , See <a href="#">Figure 24</a>	25°C	2.5 V		0.02%		
<b>SUPPLY</b>									
$I_{CC}$	Positive supply current	$V_{IN} = V_{CC}$ or GND,	Switch ON or OFF	25°C	2.7 V	10		25	nA
				Full		100			

## 6.8 Electrical Characteristics for 1.8-V Supply

 $V_{CC} = 1.65\text{ V to }1.95\text{ V}$ ,  $T_A = -40^\circ\text{C to }85^\circ\text{C}$  (unless otherwise noted)<sup>(1)</sup>

PARAMETER		TEST CONDITIONS		$T_A$	$V_{CC}$	MIN	TYP	MAX	UNIT
<b>ANALOG SWITCH</b>									
$V_{COM}$ , $V_{NO}$ , $V_{NC}$	Analog signal range					0		$V_{CC}$	V
$R_{peak}$	Peak ON resistance	$0 \leq (V_{NO} \text{ or } V_{NC}) \leq V_{CC}$ , $I_{COM} = -2\text{ mA}$ ,	Switch ON, See <a href="#">Figure 14</a>	25°C	1.65 V	5		15	$\Omega$
				Full					
$R_{on}$	ON-state resistance	$V_{NO} \text{ or } V_{NC} = 1.5\text{ V}$ , $I_{COM} = -2\text{ mA}$ ,	Switch ON, See <a href="#">Figure 14</a>	25°C	1.65 V	2		2.5	$\Omega$
				Full		3.5			
$\Delta R_{on}$	ON-state resistance match between channels	$V_{NO} \text{ or } V_{NC} = 0.6\text{ V}, 1.5\text{ V}$ , $I_{COM} = -2\text{ mA}$ ,	Switch ON, See <a href="#">Figure 14</a>	25°C	1.65 V	0.15		0.4	$\Omega$
				Full		0.4			
$R_{on(Flat)}$	ON-state resistance flatness	$0 \leq (V_{NO} \text{ or } V_{NC}) \leq V_{CC}$ , $I_{COM} = -2\text{ mA}$ ,	Switch ON, See <a href="#">Figure 14</a>	25°C	1.65 V	5			$\Omega$
				25°C		4.5			
				Full					
$I_{NO(OFF)}$ , $I_{NC(OFF)}$	NC, NO OFF leakage current	$V_{NC} \text{ or } V_{NO} = 0.3\text{ V}$ , $V_{COM} = 0.3\text{ V to }1.65\text{ V}$ , or $V_{NC} \text{ or } V_{NO} = 1.65\text{ V}$ , $V_{COM} = 0.3\text{ V to }1.65\text{ V}$	Switch OFF, See <a href="#">Figure 15</a>	25°C	1.65 V	-20	2	20	nA
				Full		-50	50		
$I_{NC(PWROFF)}$ , $I_{NO(PWROFF)}$		$V_{NC} \text{ or } V_{NO} = 0\text{ to }1.95\text{ V}$ , $V_{COM} = 1.95\text{ V to }0$ ,	Switch OFF, See <a href="#">Figure 15</a>	25°C	0 V	-1	0.1	1	$\mu\text{A}$
				Full		-5	5		
$I_{NO(ON)}$ , $I_{NC(ON)}$	NC, NO ON leakage current	$V_{NC} \text{ or } V_{NO} = 0.3\text{ V}$ , $V_{COM} = \text{Open}$ , or $V_{NC} \text{ or } V_{NO} = 1.65\text{ V}$ , $V_{COM} = \text{Open}$ ,	Switch ON, See <a href="#">Figure 16</a>	25°C	1.95 V	-5	2	5	nA
				Full		-20	20		
$I_{COM(PWROFF)}$	COM OFF leakage current	$V_{NC} \text{ or } V_{NO} = 1.95\text{ V to }0$ , $V_{COM} = 0\text{ to }1.95\text{ V}$ ,	Switch OFF, See <a href="#">Figure 15</a>	25°C	0 V	-1	0.1	1	$\mu\text{A}$
				Full		-5	5		
$I_{COM(ON)}$	COM ON leakage current	$V_{NC} \text{ or } V_{NO} = \text{Open}$ , $V_{COM} = 0.3\text{ V}$ , or $V_{NC} \text{ or } V_{NO} = \text{Open}$ , $V_{COM} = 1.65\text{ V}$ ,	Switch ON, See <a href="#">Figure 16</a>	25°C	1.95 V	-10	2	10	nA
				Full		-20	20		
<b>DIGITAL CONTROL INPUTS (IN1, IN2)</b>									
$V_{IH}$	Input logic high			Full		1.5		5.5	V
$V_{IL}$	Input logic low			Full		0		0.6	V
$I_{IH}$ , $I_{IL}$	Input leakage current	$V_{IN} = 5.5\text{ V or }0$		25°C	1.95 V	-2		2	nA
				Full		-20	20		
<b>DYNAMIC</b>									
$t_{ON}$	Turnon time	$V_{COM} = V_{CC}$ , $R_L = 50\ \Omega$ ,	$C_L = 35\text{ pF}$ , See <a href="#">Figure 18</a>	25°C	1.8 V	10	27.5	48.5	ns
				Full	1.65 V to 1.95 V	10	55		
$t_{OFF}$	Turnoff time	$V_{COM} = V_{CC}$ , $R_L = 50\ \Omega$ ,	$C_L = 35\text{ pF}$ , See <a href="#">Figure 18</a>	25°C	1.8 V	2	6.5	11	ns
				Full	1.65 V to 1.95 V	2	12		

(1) The algebraic convention, whereby the most negative value is a minimum and the most positive value is a maximum

**Electrical Characteristics for 1.8-V Supply (continued)**
 $V_{CC} = 1.65\text{ V to }1.95\text{ V}$ ,  $T_A = -40^\circ\text{C to }85^\circ\text{C}$  (unless otherwise noted)<sup>(1)</sup>

PARAMETER		TEST CONDITIONS		$T_A$	$V_{CC}$	MIN	TYP	MAX	UNIT
$t_{BBM}$	Break-before-make time	$V_{NC} = V_{NO} = V_{CC}$ , $R_L = 50\ \Omega$ ,	$C_L = 35\text{ pF}$ , See <a href="#">Figure 19</a>	25°C	1.8 V	1	18	50	ns
				Full	1.65 V to 1.95 V	1		55	
$Q_C$	Charge injection	$V_{GEN} = 0$ , $R_{GEN} = 0$ ,	$C_L = 1\text{ nF}$ , See <a href="#">Figure 23</a>	25°C	1.8 V		2		pC
$C_{NC(OFF)}$ , $C_{NO(OFF)}$	NC, NO OFF capacitance	$V_{NC}$ or $V_{NO} = V_{CC}$ or GND, Switch OFF,	See <a href="#">Figure 17</a>	25°C	1.8 V		18.5		pF
$C_{NC(ON)}$ , $C_{NO(ON)}$	NC, NO ON capacitance	$V_{NC}$ or $V_{NO} = V_{CC}$ or GND, Switch ON,	See <a href="#">Figure 17</a>	25°C	1.8 V		56.5		pF
$C_{COM(ON)}$	COM ON capacitance	$V_{COM} = V_{CC}$ or GND, Switch ON,	See <a href="#">Figure 17</a>	25°C	1.8 V		56.5		pF
$C_I$	Digital input capacitance	$V_{IN} = V_{CC}$ or GND,	See <a href="#">Figure 17</a>	25°C	1.8 V		2		pF
BW	Bandwidth	$R_L = 50\ \Omega$ , Switch ON,	See <a href="#">Figure 20</a>	25°C	1.8 V		105		MHz
$O_{ISO}$	OFF isolation	$R_L = 50\ \Omega$ , $f = 1\text{ MHz}$ ,	Switch OFF, See <a href="#">Figure 21</a>	25°C	1.8 V		-64		dB
$X_{TALK}$	Crosstalk	$R_L = 50\ \Omega$ , $f = 1\text{ MHz}$ ,	Switch ON, See <a href="#">Figure 22</a>	25°C	1.8 V		-64		dB
THD	Total harmonic distortion	$R_L = 600\ \Omega$ , $C_L = 50\text{ pF}$ ,	$f = 20\text{ Hz to }20\text{ kHz}$ , See <a href="#">Figure 24</a>	25°C	1.8 V		0.06%		
<b>SUPPLY</b>									
$I_{CC}$	Positive supply current	$V_{IN} = V_{CC}$ or GND,	Switch ON or OFF	25°C	1.95 V		10	25	nA
				Full				50	

### 6.9 Typical Characteristics

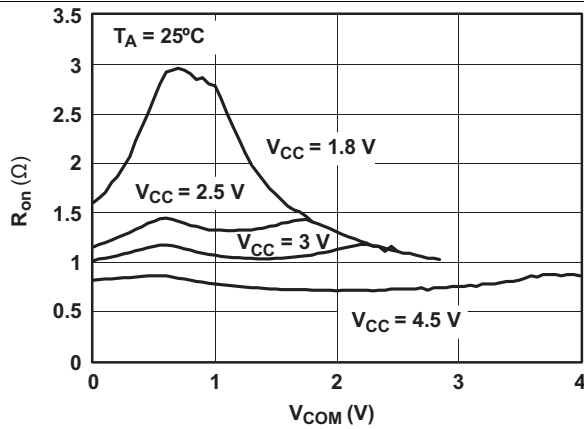


Figure 1.  $R_{on}$  vs  $V_{COM}$

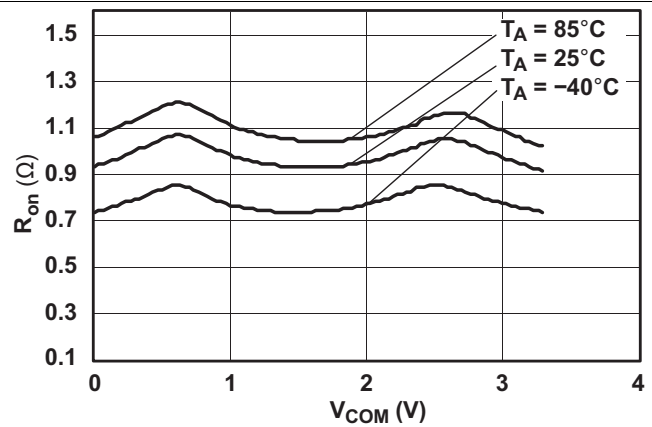


Figure 2.  $R_{on}$  vs  $V_{COM}$  ( $V_{CC} = 3.3\text{ V}$ )

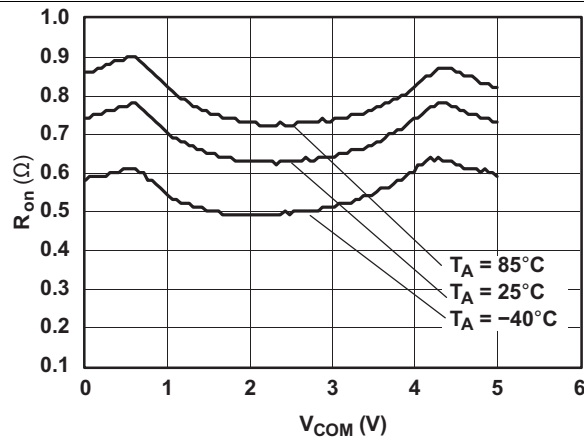


Figure 3.  $R_{on}$  vs  $V_{COM}$  ( $V_{CC} = 5\text{ V}$ )

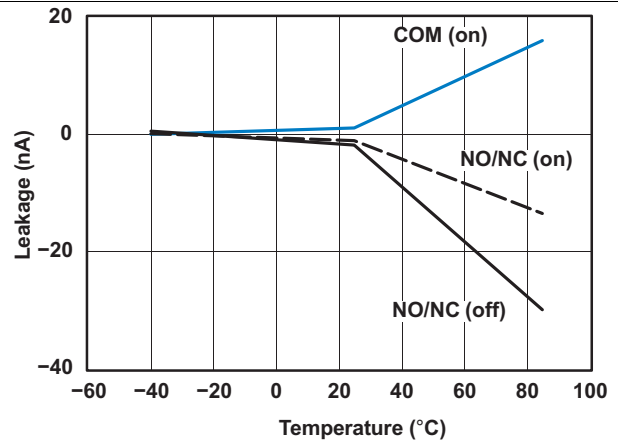


Figure 4. Leakage Current vs Temperature ( $V_{CC} = 3.3\text{ V}$ )

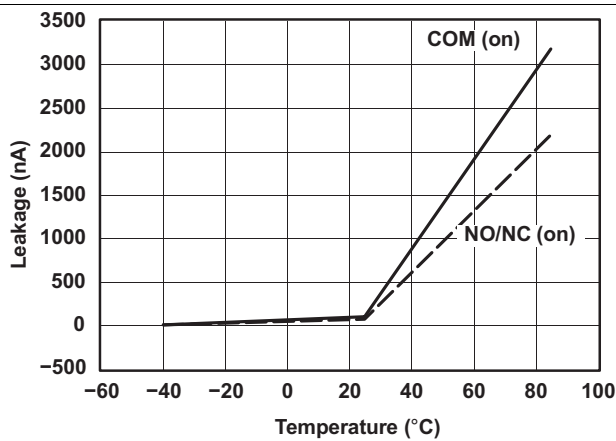


Figure 5. Leakage Current vs Temperature ( $V_{CC} = 5\text{ V}$ )

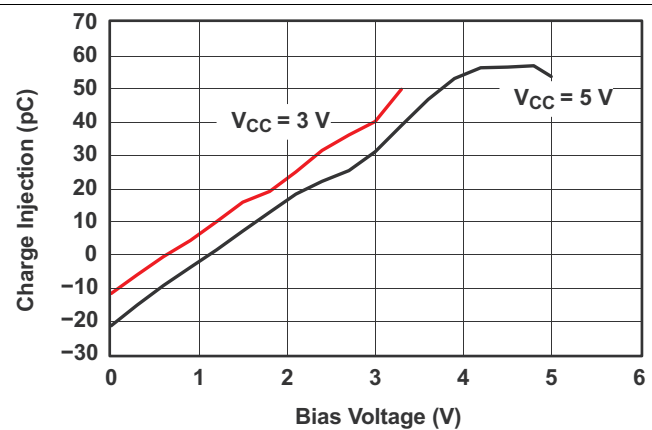
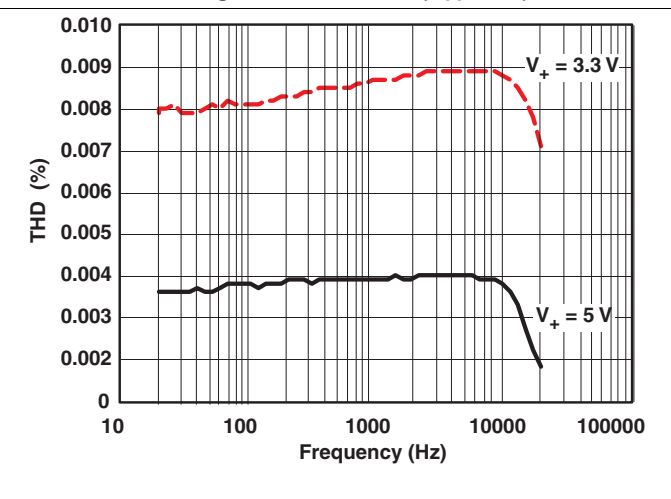
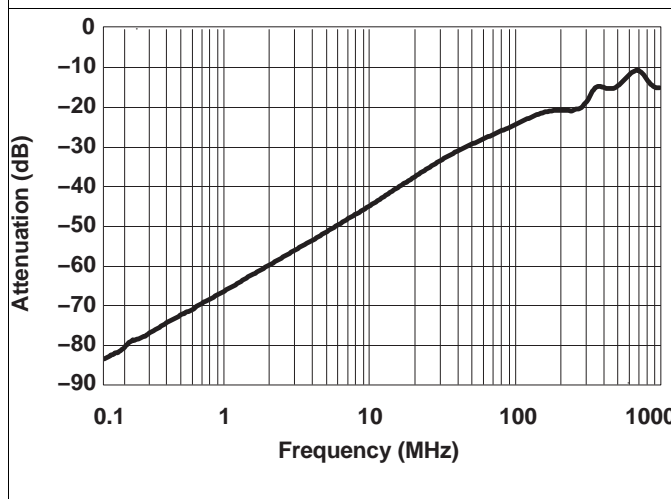
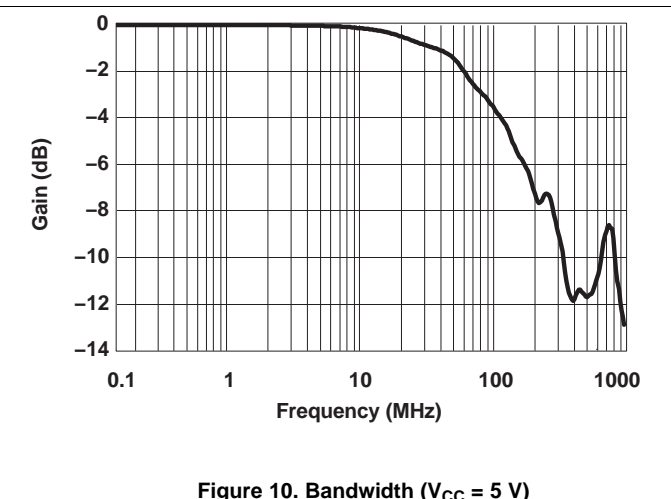
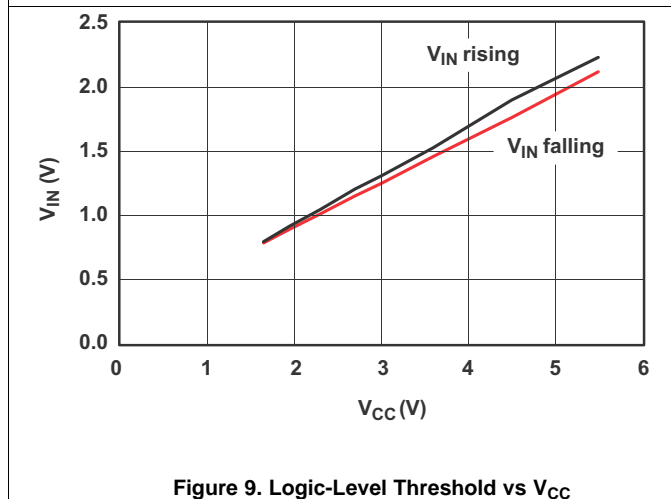
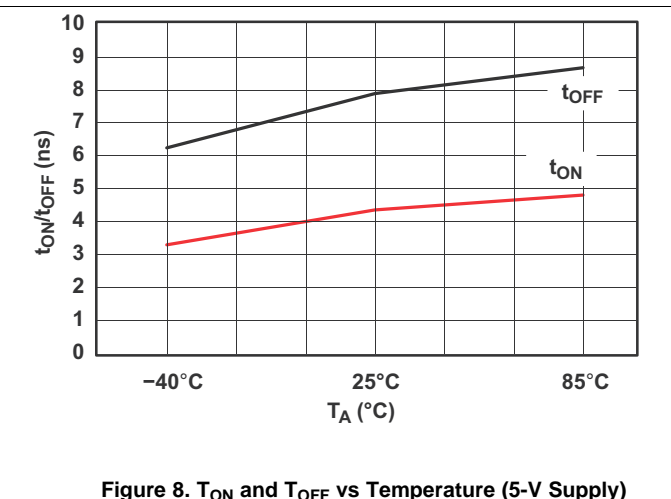
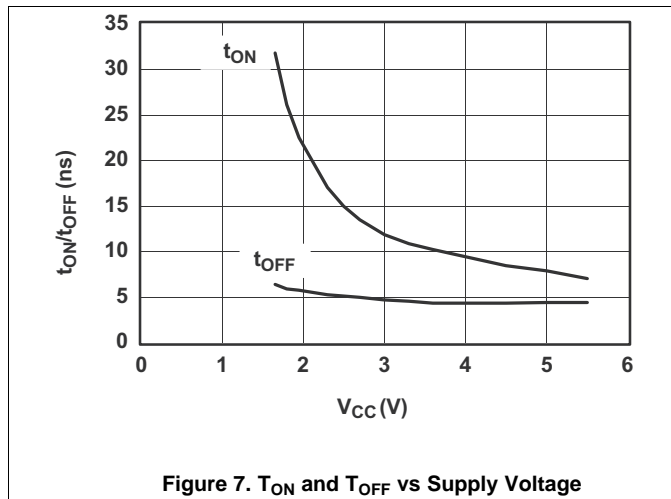
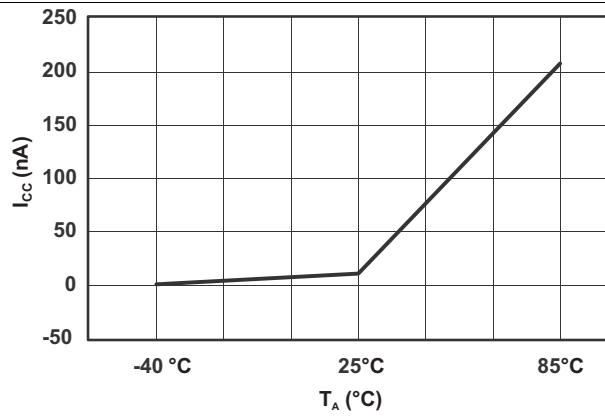


Figure 6. Charge Injection ( $Q_C$ ) vs  $V_{COM}$

Typical Characteristics (continued)

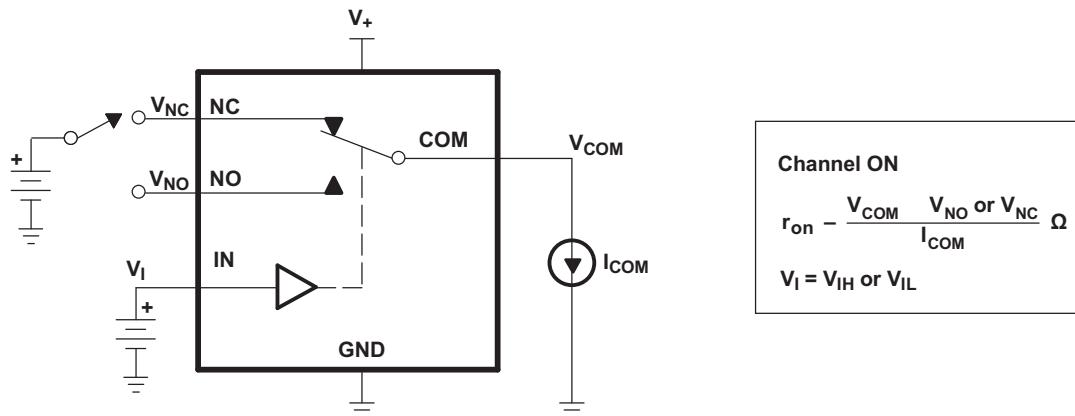


**Typical Characteristics (continued)**

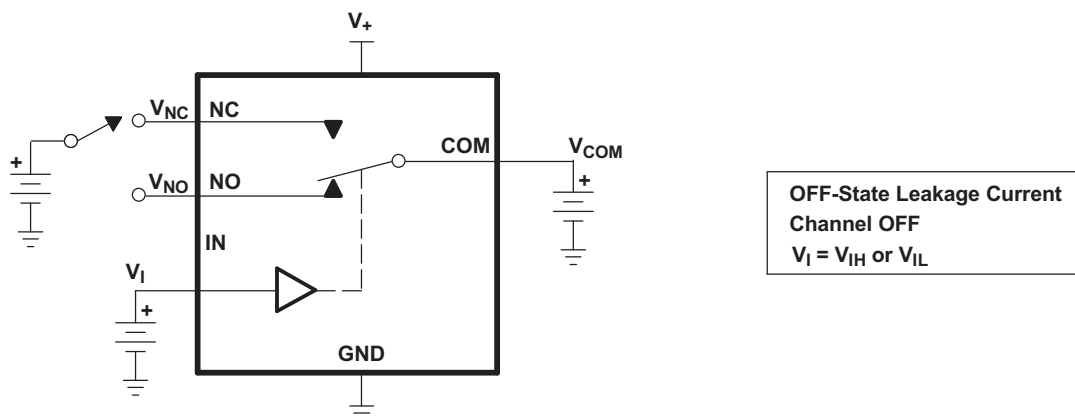


**Figure 13. Power-Supply Current vs Temperature ( $V_{CC} = 5\text{ V}$ )**

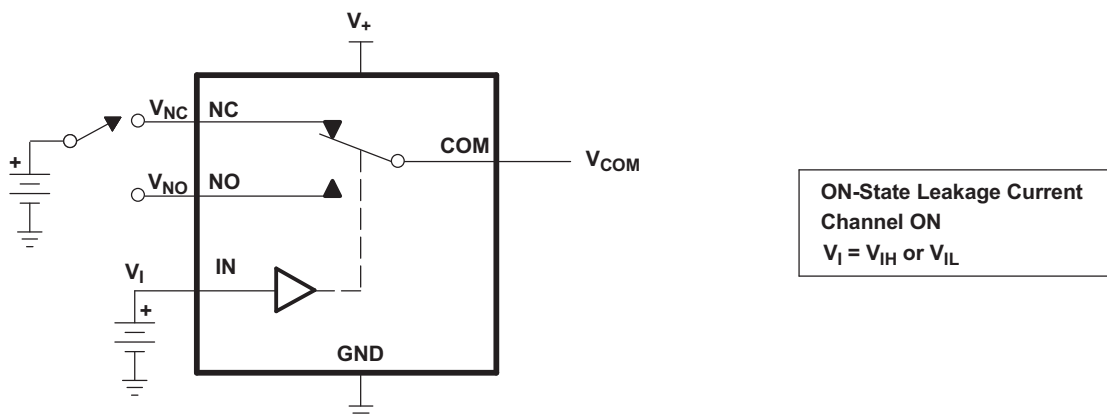
## 7 Parameter Measurement Information



**Figure 14. ON-State Resistance ( $R_{on}$ )**



**Figure 15. OFF-State Leakage Current**  
( $I_{NC(OFF)}$ ,  $I_{NC(PWROFF)}$ ,  $I_{NO(OFF)}$ ,  $I_{NO(PWROFF)}$ ,  $I_{COM(OFF)}$ ,  $I_{COM(PWROFF)}$ )



**Figure 16. ON-State Leakage Current ( $I_{COM(ON)}$ ,  $I_{NC(ON)}$ ,  $I_{NO(ON)}$ )**

Parameter Measurement Information (continued)

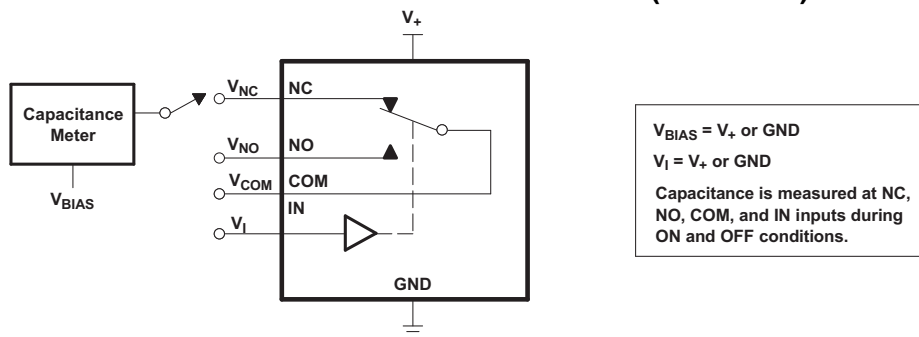
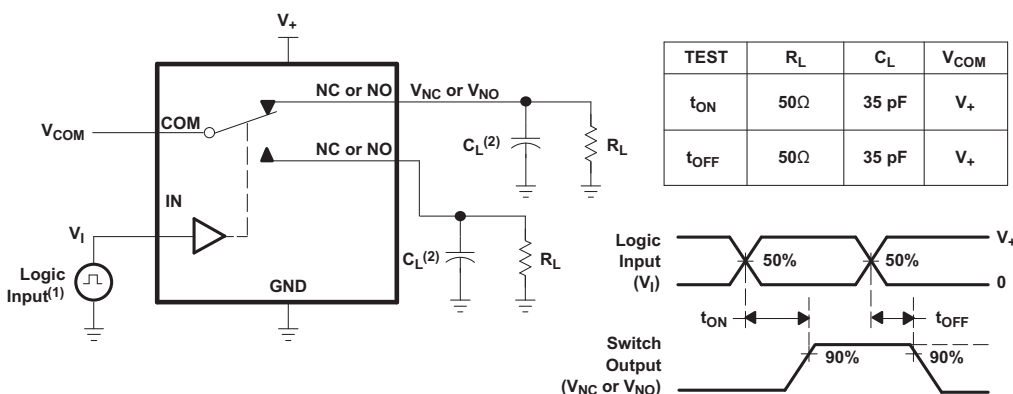
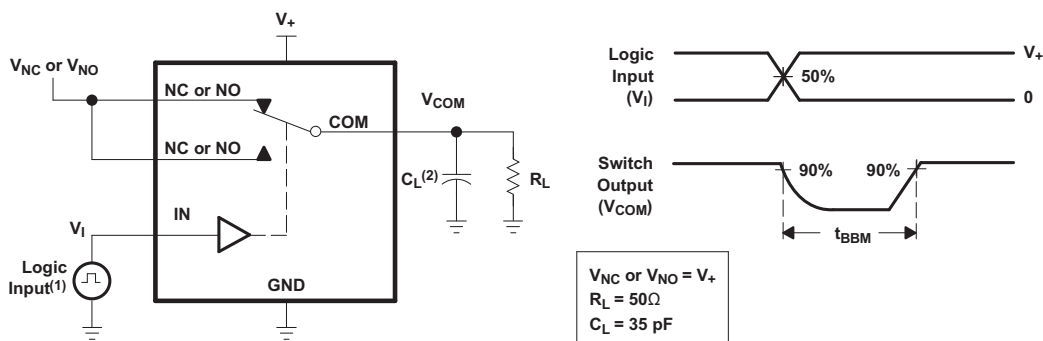


Figure 17. Capacitance ( $C_I$ ,  $C_{COM(ON)}$ ,  $C_{NC(OFF)}$ ,  $C_{NO(OFF)}$ ,  $C_{NC(ON)}$ ,  $C_{NO(ON)}$ )



1. All input pulses are supplied by generators having the following characteristics:  
 PRR 3 10 MHz,  $Z_O = 50 \Omega$ ,  $t_r < 5 \text{ ns}$ ,  $t_f < 5 \text{ ns}$ .
2.  $C_L$  includes probe and jig capacitance.

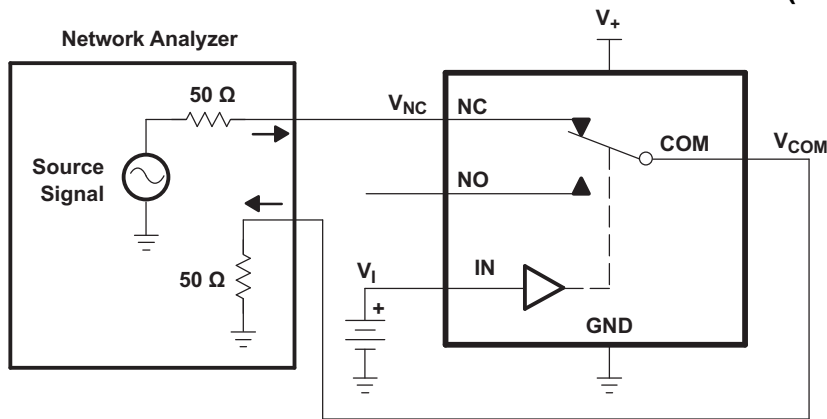
Figure 18. Turnon ( $T_{ON}$ ) and Turnoff Time ( $T_{OFF}$ )



1. All input pulses are supplied by generators having the following characteristics:  
 PRR 3 10 MHz,  $Z_O = 50 \Omega$ ,  $t_r < 5 \text{ ns}$ ,  $t_f < 5 \text{ ns}$ .
2.  $C_L$  includes probe and jig capacitance.

Figure 19. Break-Before-Make Time ( $T_{BBM}$ )

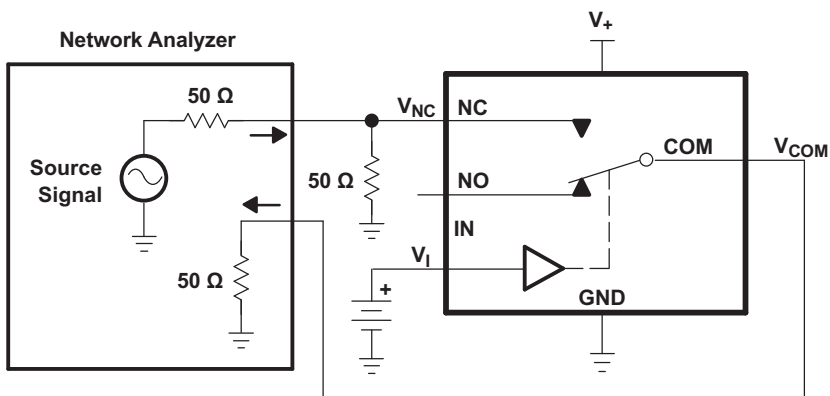
**Parameter Measurement Information (continued)**



Channel ON: NC to COM  
 $V_I = V_+$  or GND

**Network Analyzer Setup**  
 Source Power = 0 dBm  
 (632-mV P-P at 50-Ω load)  
 DC Bias = 350 mV

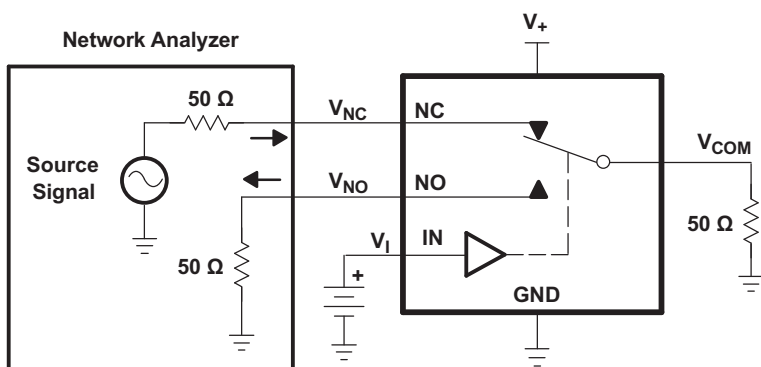
**Figure 20. Bandwidth (Bw)**



Channel OFF: NC to COM  
 $V_I = V_+$  or GND

**Network Analyzer Setup**  
 Source Power = 0 dBm  
 (632-mV P-P at 50-Ω load)  
 DC Bias = 350 mV

**Figure 21. Off Isolation ( $O_{ISO}$ )**

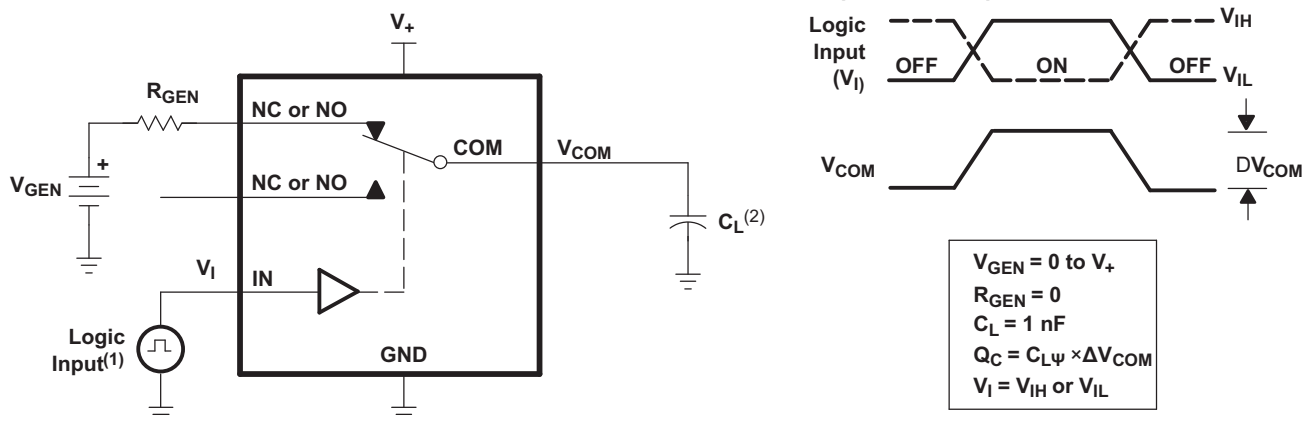


Channel ON: NC to COM  
 Channel OFF: NO to COM  
 $V_I = V_+$  or GND

**Network Analyzer Setup**  
 Source Power = 0 dBm  
 (632-mV P-P at 50-Ω load)  
 DC Bias = 350 mV

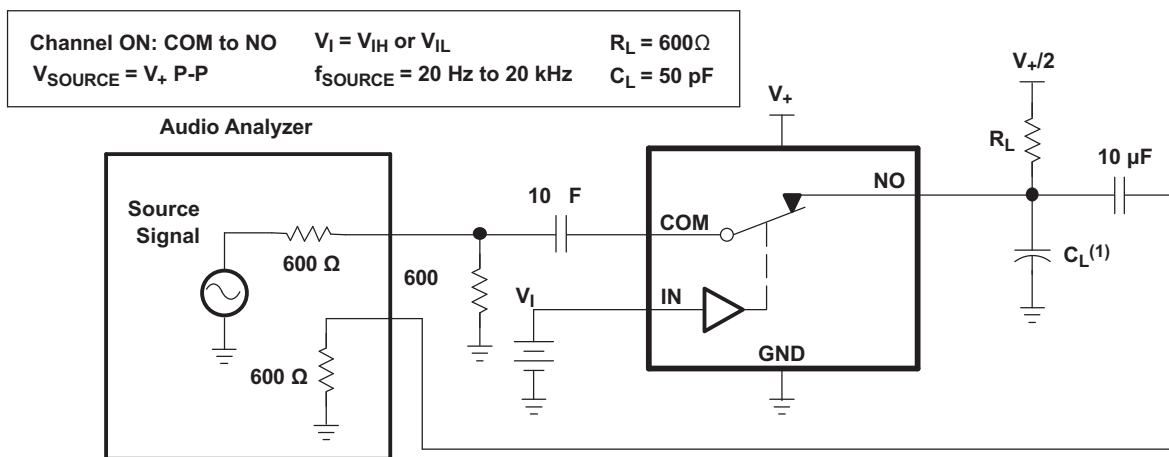
**Figure 22. Crosstalk ( $X_{TALK}$ )**

Parameter Measurement Information (continued)



1. All input pulses are supplied by generators having the following characteristics:  
 PRR 3 10 MHz,  $Z_O = 50 \Omega$ ,  $t_r < 5 \text{ ns}$ ,  $t_f < 5 \text{ ns}$ .
2.  $C_L$  includes probe and jig capacitance.

Figure 23. Charge Injection ( $Q_C$ )



1.  $C_L$  includes probe and jig capacitance.

Figure 24. Total Harmonic Distortion (THD)

**Parameter Measurement Information (continued)**  
**Table 1. Parameter Description**

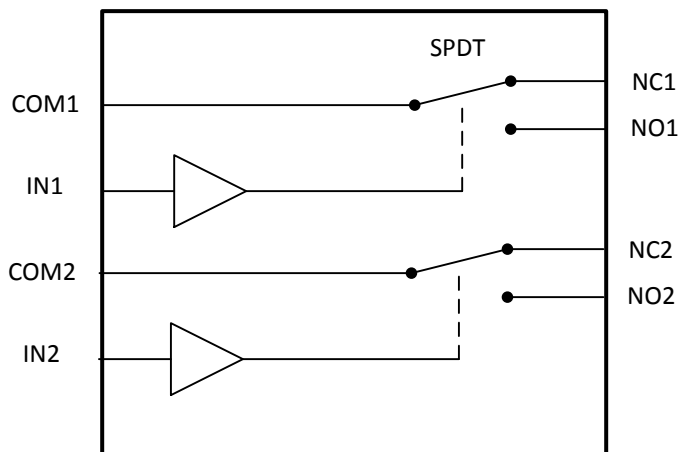
<b>SYMBOL</b>	<b>DESCRIPTION</b>
$V_{COM}$	Voltage at COM
$V_{NC}$	Voltage at NC
$V_{NO}$	Voltage at NO
$R_{on}$	Resistance between COM and NC or COM and NO ports when the channel is ON
$R_{peak}$	Peak on-state resistance over a specified voltage range
$\Delta R_{on}$	Difference of $R_{on}$ between channels in a specific device
$R_{on(flat)}$	Difference between the maximum and minimum value of $R_{on}$ in a channel over the specified range of conditions
$I_{NC(OFF)}$	Leakage current measured at the NC port, with the corresponding channel (NC to COM) in the OFF state under worst-case input and output conditions
$I_{NC(PWROFF)}$	Leakage current measured at the NC port during the power-down condition, $V_{CC} = 0$
$I_{NO(OFF)}$	Leakage current measured at the NO port, with the corresponding channel (NO to COM) in the OFF state under worst-case input and output conditions
$I_{NO(PWROFF)}$	Leakage current measured at the NO port during the power-down condition, $V_{CC} = 0$
$I_{NC(ON)}$	Leakage current measured at the NC port, with the corresponding channel (NC to COM) in the ON state and the output (COM) open
$I_{NO(ON)}$	Leakage current measured at the NO port, with the corresponding channel (NO to COM) in the ON state and the output (COM) open
$I_{COM(ON)}$	Leakage current measured at the COM port, with the corresponding channel (COM to NO or COM to NC) in the ON state and the output (NC or NO) open
$I_{COM(PWROFF)}$	Leakage current measured at the COM port during the power-down condition, $V_{CC} = 0$
$V_{IH}$	Minimum input voltage for logic high for the control input (IN)
$V_{IL}$	Maximum input voltage for logic low for the control input (IN)
$V_{IN}$	Voltage at the control input (IN)
$I_{IH}, I_{IL}$	Leakage current measured at the control input (IN)
$t_{ON}$	Turnon time for the switch. This parameter is measured under the specified range of conditions and by the propagation delay between the digital control (IN) signal and analog output (COM, NC, or NO) signal when the switch is turning ON.
$t_{OFF}$	Turnoff time for the switch. This parameter is measured under the specified range of conditions and by the propagation delay between the digital control (IN) signal and analog output (COM, NC, or NO) signal when the switch is turning OFF.
$t_{BBM}$	Break-before-make time. This parameter is measured under the specified range of conditions and by the propagation delay between the output of two adjacent analog channels (NC and NO) when the control signal changes state.
$Q_C$	Charge injection is a measurement of unwanted signal coupling from the control (IN) input to the analog (NO or COM) output. This is measured in coulomb (C) and measured by the total charge induced due to switching of the control input. Charge injection, $Q_C = C_L \times \Delta V_{COM}$ . $C_L$ is the load capacitance and $\Delta V_{COM}$ is the change in analog output voltage.
$C_{NC(OFF)}$	Capacitance at the NC port when the corresponding channel (NC to COM) is OFF
$C_{NO(OFF)}$	Capacitance at the NO port when the corresponding channel (NO to COM) is OFF
$C_{NC(ON)}$	Capacitance at the NC port when the corresponding channel (NC to COM) is ON
$C_{NO(ON)}$	Capacitance at the NO port when the corresponding channel (NO to COM) is ON
$C_{COM(ON)}$	Capacitance at the COM port when the corresponding channel (COM to NC or COM to NO) is ON
$C_I$	Capacitance of control input (IN)
$O_{ISO}$	OFF isolation of the switch is a measurement of OFF-state switch impedance. This is measured in dB in a specific frequency, with the corresponding channel (NC to COM or NO to COM) in the OFF state.
$X_{TALK}$	Crosstalk is a measurement of unwanted signal coupling from an ON channel to an OFF channel (NC to NO or NO to NC). This is measured in a specific frequency and in dB.
BW	Bandwidth of the switch. This is the frequency in which the gain of an ON channel is –3 dB below the DC gain.
THD	Total harmonic distortion is defined as the ratio of the root mean square (RMS) value of the second, third, and higher harmonics to the magnitude of fundamental harmonic.
$I_{CC}$	Static power-supply current with the control (IN) pin at $V_{CC}$ or GND

## 8 Detailed Description

### 8.1 Overview

The TS5A23159 is a bidirectional 2-channel single-pole double-throw (SPDT) switch that is designed to operate from 1.65 V to 5.5 V. The device offers low ON-state resistance and excellent ON-state resistance matching with the break-before-make feature which prevents signal distortion during the transferring of a signal from one channel to another. The device has an excellent total harmonic distortion (THD) performance and consumes very low power. These features make this device suitable for a wide variety of portable applications including cell phones, audio devices, and instrumentation.

### 8.2 Functional Block Diagram



### 8.3 Feature Description

The TS5A23159 is a bidirectional device that has two single-pole, double-throw switches. The two channels of the switch are controlled independently by two digital signals; one digital control for each single-pole, double-throw switch.

### 8.4 Device Functional Modes

**Table 2. Function Table**

IN	NC to COM, COM to NC	NO to COM, COM to NO
L	ON	OFF
H	OFF	ON

## 9 Application and Implementation

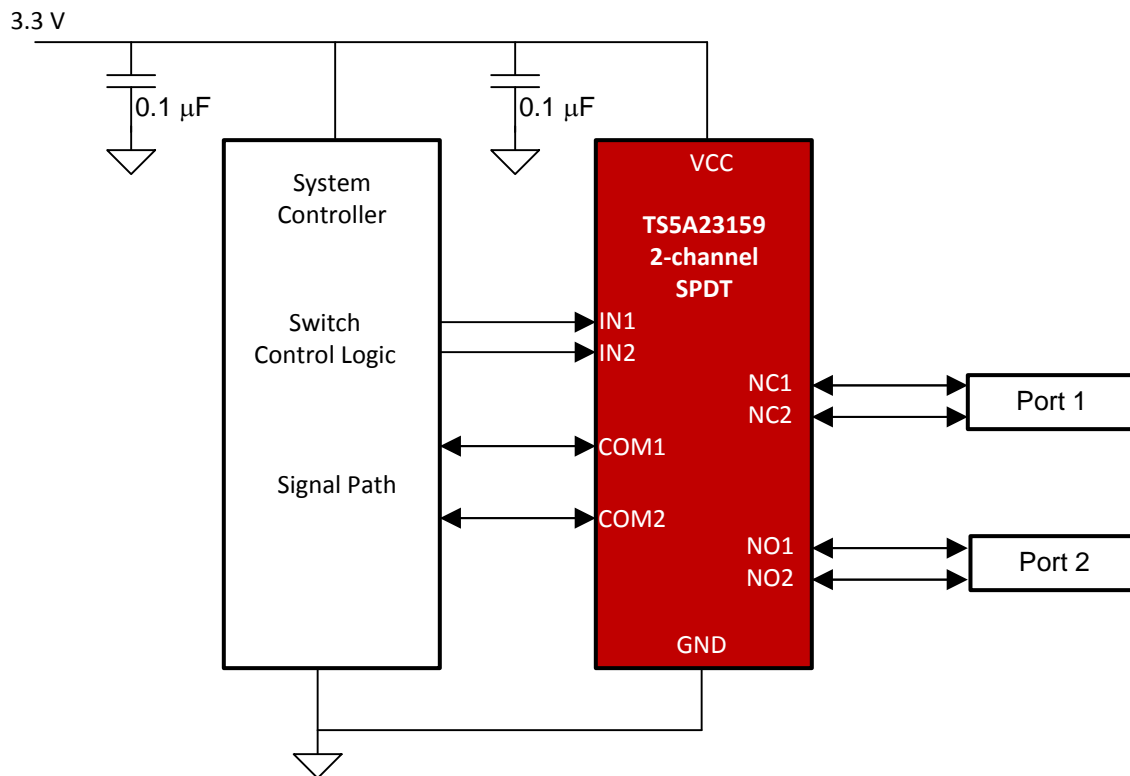
### NOTE

Information in the following applications sections is not part of the TI component specification, and TI does not warrant its accuracy or completeness. TI's customers are responsible for determining suitability of components for their purposes. Customers should validate and test their design implementation to confirm system functionality.

### 9.1 Application Information

The switches are bidirectional, so the NO, NC, and COM pins can be used as either inputs or outputs.

### 9.2 Typical Application



**Figure 25. Typical Application Diagram**

#### 9.2.1 Design Requirements

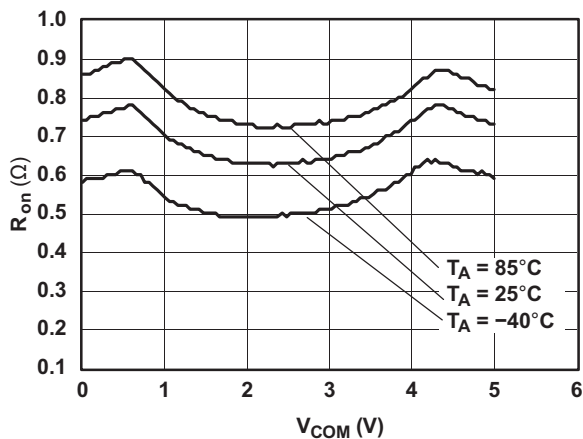
Ensure that all of the signals passing through the switch are within the specified ranges in the recommended operating conditions to ensure proper performance.

#### 9.2.2 Detailed Design Procedure

The TS5A23159 can be properly operated without any external components. However, TI recommends connecting unused pins to ground through a 50-Ω resistor to prevent signal reflections back into the device. TI also recommends that the digital control pins (INX) be pulled up to VCC or down to GND to avoid undesired switch positions that could result from the floating pin.

**Typical Application (continued)**

**9.2.3 Application Curve**



**Figure 26.  $R_{on}$  vs  $V_{COM}$  ( $V_{CC} = 5$  V)**

**10 Power Supply Recommendations**

Proper power-supply sequencing is recommended for all CMOS devices. Do not exceed the absolute maximum ratings, because stresses beyond the listed ratings can cause permanent damage to the device. Always sequence VCC on first, followed by NO, NC, or COM. Although it is not required, power-supply bypassing improves noise margin and prevents switching noise propagation from the VCC supply to other components. A 0.1- $\mu\text{F}$  capacitor, connected from VCC to GND, is adequate for most applications.

## 11 Layout

### 11.1 Layout Guidelines

High-speed switches require proper layout and design procedures for optimum performance. Reduce stray inductance and capacitance by keeping traces short and wide. Ensure that bypass capacitors are as close to the device as possible. Use large ground planes where possible.

### 11.2 Layout Example

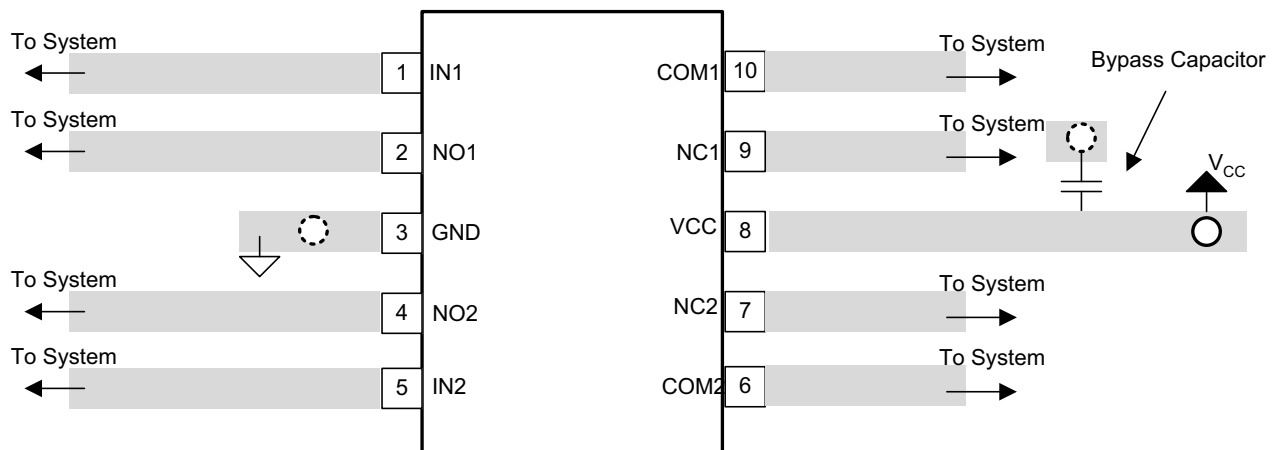
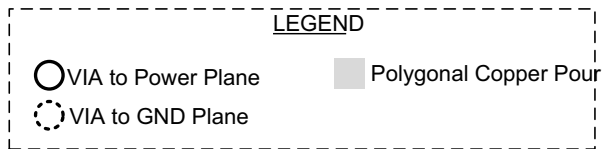


Figure 27. Layout Recommendation

## 12 Device and Documentation Support

### 12.1 Trademarks

All trademarks are the property of their respective owners.

### 12.2 Electrostatic Discharge Caution



These devices have limited built-in ESD protection. The leads should be shorted together or the device placed in conductive foam during storage or handling to prevent electrostatic damage to the MOS gates.

### 12.3 Glossary

[SLYZ022](#) — *TI Glossary*.

This glossary lists and explains terms, acronyms, and definitions.

## 13 Mechanical, Packaging, and Orderable Information

The following pages include mechanical, packaging, and orderable information. This information is the most current data available for the designated devices. This data is subject to change without notice and revision of this document. For browser-based versions of this data sheet, refer to the left-hand navigation.

**PACKAGING INFORMATION**

Orderable Device	Status (1)	Package Type	Package Drawing	Pins	Package Qty	Eco Plan (2)	Lead/Ball Finish (6)	MSL Peak Temp (3)	Op Temp (°C)	Device Marking (4/5)	Samples
TS5A23159DGSR	ACTIVE	VSSOP	DGS	10	2500	Green (RoHS & no Sb/Br)	CU NIPDAU	Level-1-260C-UNLIM	-40 to 85	(JEQ ~ JER)	<a href="#">Samples</a>
TS5A23159DGSRG4	ACTIVE	VSSOP	DGS	10	2500	Green (RoHS & no Sb/Br)	CU NIPDAU	Level-1-260C-UNLIM	-40 to 85	(JEQ ~ JER)	<a href="#">Samples</a>
TS5A23159DGST	ACTIVE	VSSOP	DGS	10	250	Green (RoHS & no Sb/Br)	CU NIPDAU	Level-1-260C-UNLIM	-40 to 85	JER	<a href="#">Samples</a>
TS5A23159DGSTE4	ACTIVE	VSSOP	DGS	10	250	Green (RoHS & no Sb/Br)	CU NIPDAU	Level-1-260C-UNLIM	-40 to 85	JER	<a href="#">Samples</a>
TS5A23159DGSTG4	ACTIVE	VSSOP	DGS	10	250	Green (RoHS & no Sb/Br)	CU NIPDAU	Level-1-260C-UNLIM	-40 to 85	JER	<a href="#">Samples</a>
TS5A23159RSER	ACTIVE	UQFN	RSE	10	3000	Green (RoHS & no Sb/Br)	CU NIPDAU   CU NIPDAUAG	Level-1-260C-UNLIM	-40 to 85	(JE7 ~ JEO ~ JER)	<a href="#">Samples</a>
TS5A23159RSERG4	ACTIVE	UQFN	RSE	10	3000	Green (RoHS & no Sb/Br)	CU NIPDAU	Level-1-260C-UNLIM	-40 to 85	(JE7 ~ JEO ~ JER)	<a href="#">Samples</a>

(1) The marketing status values are defined as follows:

**ACTIVE:** Product device recommended for new designs.

**LIFEBUY:** TI has announced that the device will be discontinued, and a lifetime-buy period is in effect.

**NRND:** Not recommended for new designs. Device is in production to support existing customers, but TI does not recommend using this part in a new design.

**PREVIEW:** Device has been announced but is not in production. Samples may or may not be available.

**OBSOLETE:** TI has discontinued the production of the device.

(2) Eco Plan - The planned eco-friendly classification: Pb-Free (RoHS), Pb-Free (RoHS Exempt), or Green (RoHS & no Sb/Br) - please check <http://www.ti.com/productcontent> for the latest availability information and additional product content details.

**TBD:** The Pb-Free/Green conversion plan has not been defined.

**Pb-Free (RoHS):** TI's terms "Lead-Free" or "Pb-Free" mean semiconductor products that are compatible with the current RoHS requirements for all 6 substances, including the requirement that lead not exceed 0.1% by weight in homogeneous materials. Where designed to be soldered at high temperatures, TI Pb-Free products are suitable for use in specified lead-free processes.

**Pb-Free (RoHS Exempt):** This component has a RoHS exemption for either 1) lead-based flip-chip solder bumps used between the die and package, or 2) lead-based die adhesive used between the die and leadframe. The component is otherwise considered Pb-Free (RoHS compatible) as defined above.

**Green (RoHS & no Sb/Br):** TI defines "Green" to mean Pb-Free (RoHS compatible), and free of Bromine (Br) and Antimony (Sb) based flame retardants (Br or Sb do not exceed 0.1% by weight in homogeneous material)

(3) MSL, Peak Temp. - The Moisture Sensitivity Level rating according to the JEDEC industry standard classifications, and peak solder temperature.

(4) There may be additional marking, which relates to the logo, the lot trace code information, or the environmental category on the device.

<sup>(5)</sup> Multiple Device Markings will be inside parentheses. Only one Device Marking contained in parentheses and separated by a "-" will appear on a device. If a line is indented then it is a continuation of the previous line and the two combined represent the entire Device Marking for that device.

<sup>(6)</sup> Lead/Ball Finish - Orderable Devices may have multiple material finish options. Finish options are separated by a vertical ruled line. Lead/Ball Finish values may wrap to two lines if the finish value exceeds the maximum column width.

**Important Information and Disclaimer:**The information provided on this page represents TI's knowledge and belief as of the date that it is provided. TI bases its knowledge and belief on information provided by third parties, and makes no representation or warranty as to the accuracy of such information. Efforts are underway to better integrate information from third parties. TI has taken and continues to take reasonable steps to provide representative and accurate information but may not have conducted destructive testing or chemical analysis on incoming materials and chemicals. TI and TI suppliers consider certain information to be proprietary, and thus CAS numbers and other limited information may not be available for release.

In no event shall TI's liability arising out of such information exceed the total purchase price of the TI part(s) at issue in this document sold by TI to Customer on an annual basis.

**TAPE AND REEL INFORMATION**

**QUADRANT ASSIGNMENTS FOR PIN 1 ORIENTATION IN TAPE**


\*All dimensions are nominal

Device	Package Type	Package Drawing	Pins	SPQ	Reel Diameter (mm)	Reel Width W1 (mm)	A0 (mm)	B0 (mm)	K0 (mm)	P1 (mm)	W (mm)	Pin1 Quadrant
TS5A23159DGSR	VSSOP	DGS	10	2500	330.0	12.4	5.3	3.4	1.4	8.0	12.0	Q1
TS5A23159DGST	VSSOP	DGS	10	250	330.0	12.4	5.3	3.4	1.4	8.0	12.0	Q1
TS5A23159RSER	UQFN	RSE	10	3000	179.0	8.4	1.75	2.25	0.65	4.0	8.0	Q1
TS5A23159RSER	UQFN	RSE	10	3000	180.0	8.4	1.68	2.13	0.76	4.0	8.0	Q1
TS5A23159RSER	UQFN	RSE	10	3000	180.0	9.5	1.7	2.3	0.75	4.0	8.0	Q1

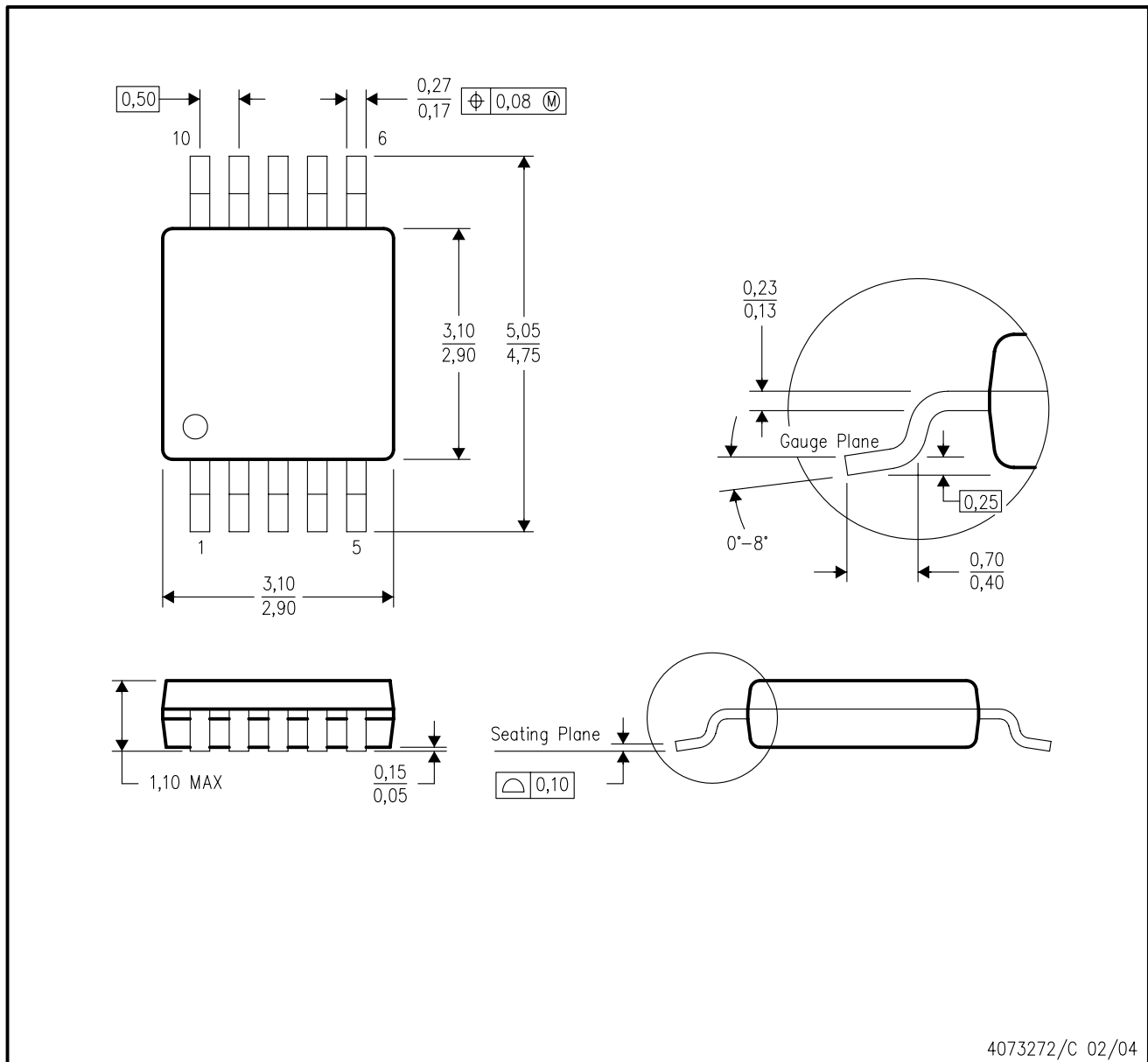
**TAPE AND REEL BOX DIMENSIONS**


\*All dimensions are nominal

Device	Package Type	Package Drawing	Pins	SPQ	Length (mm)	Width (mm)	Height (mm)
TS5A23159DGSR	VSSOP	DGS	10	2500	358.0	335.0	35.0
TS5A23159DGST	VSSOP	DGS	10	250	358.0	335.0	35.0
TS5A23159RSER	UQFN	RSE	10	3000	203.0	203.0	35.0
TS5A23159RSER	UQFN	RSE	10	3000	202.0	201.0	28.0
TS5A23159RSER	UQFN	RSE	10	3000	184.0	184.0	19.0

DGS (S-PDSO-G10)

PLASTIC SMALL-OUTLINE PACKAGE

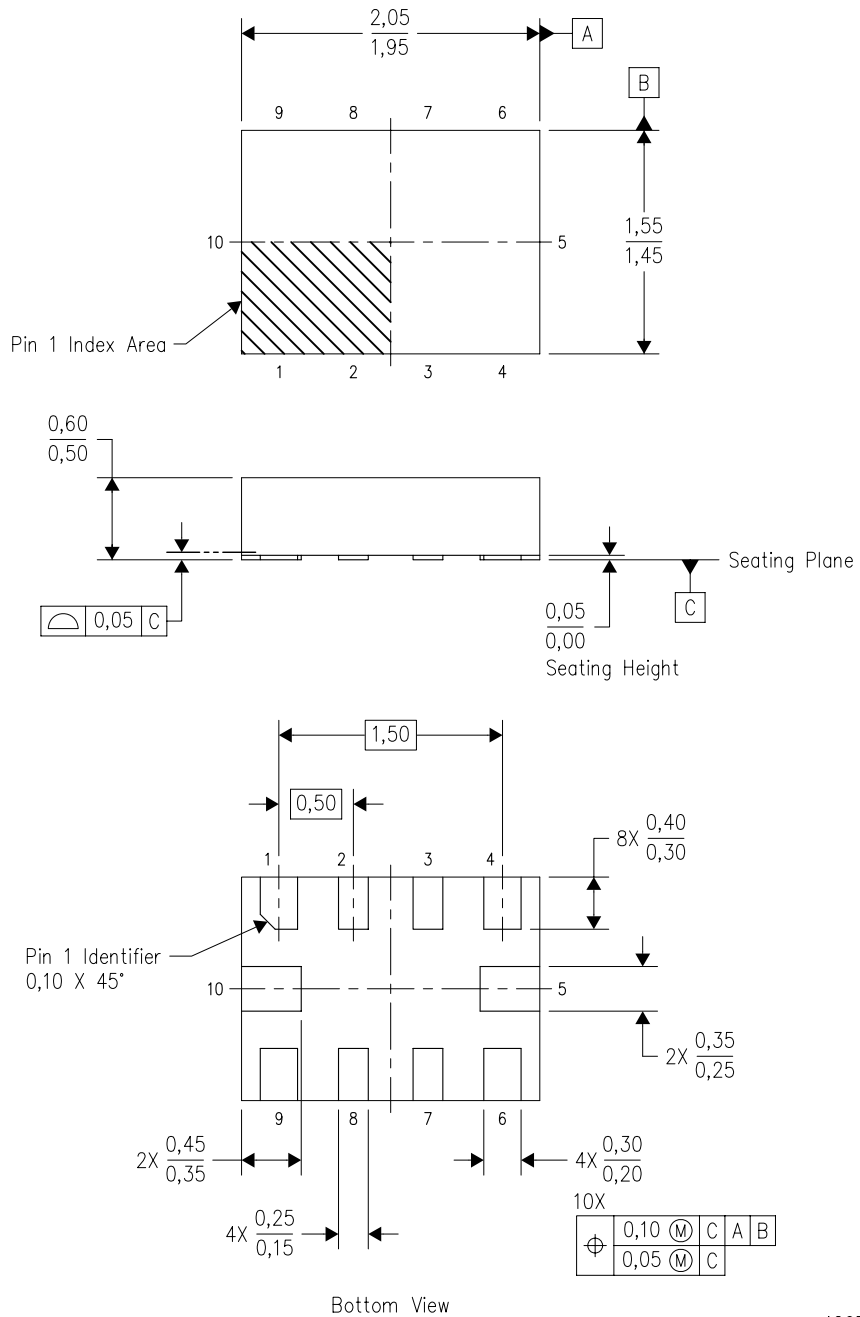


- NOTES:
- A. All linear dimensions are in millimeters.
  - B. This drawing is subject to change without notice.
  - C. Body dimensions do not include mold flash or protrusion.
  - D. Falls within JEDEC MO-187 variation BA.



RSE (R-PUQFN-N10)

PLASTIC QUAD FLATPACK NO-LEAD

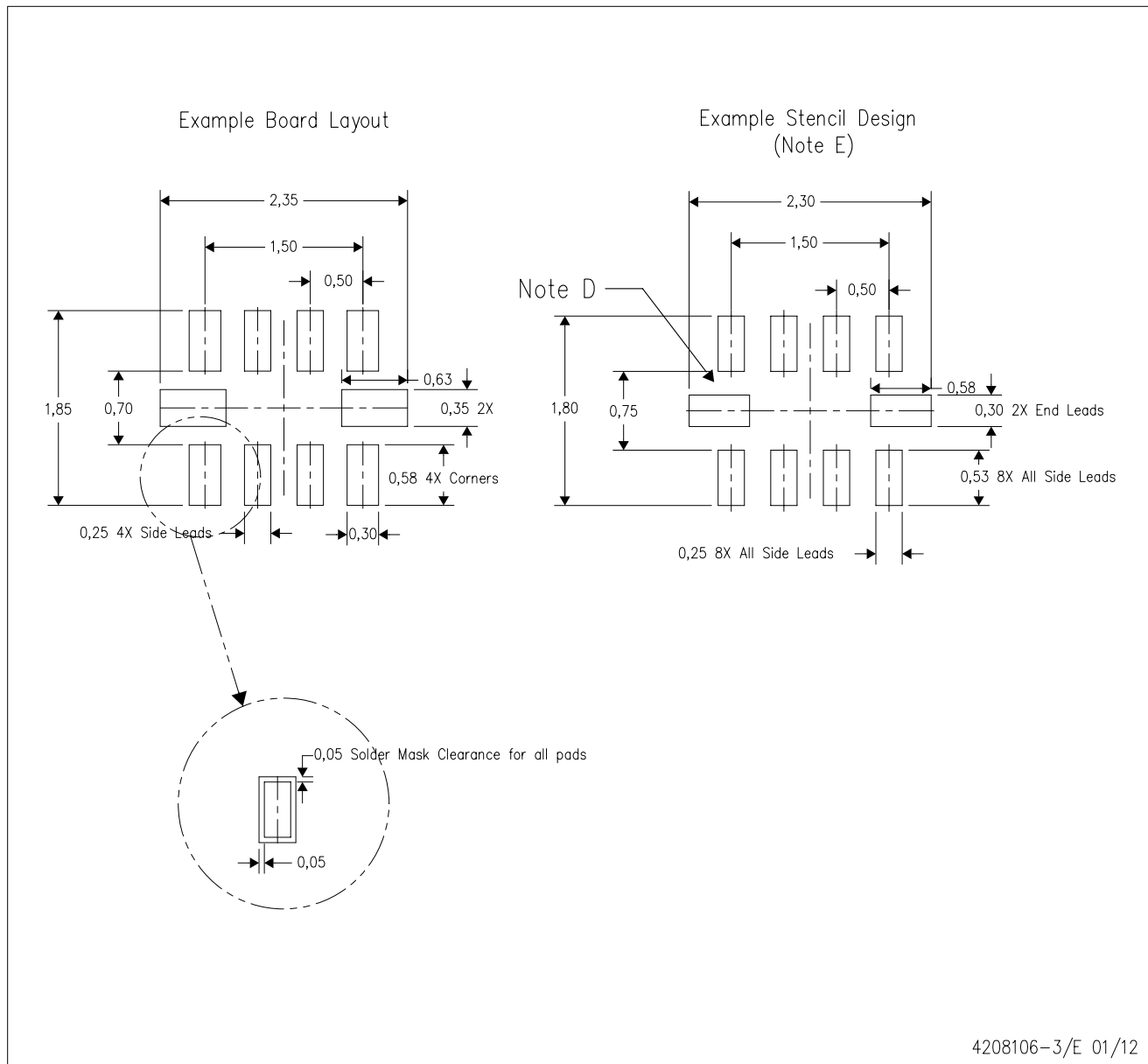


4207268-3/D 01/11

- NOTES:
- A. All linear dimensions are in millimeters. Dimensioning and tolerancing per ASME Y14.5M-1994.
  - B. This drawing is subject to change without notice.
  - C. QFN (Quad Flatpack No-Lead) package configuration.
  - D. This package complies to JEDEC MO-288 variation UDFD.

RSE (R-PUQFN-N10)

PLASTIC QUAD FLATPACK NO-LEAD



- NOTES:
- A. All linear dimensions are in millimeters.
  - B. This drawing is subject to change without notice.
  - C. Publication IPC-7351 is recommended for alternate designs.
  - D. Customers should contact their board fabrication site for minimum solder mask web tolerances between signal pads.
  - E. Maximum stencil thickness 0,127 mm (5 mils). All linear dimensions are in millimeters.
  - F. Laser cutting apertures with trapezoidal walls and also rounding corners will offer better paste release. Customers should contact their board assembly site for stencil design recommendations. Refer to IPC 7525 for stencil design considerations.
  - G. Side aperture dimensions over-print land for acceptable area ratio > 0.66. Customer may reduce side aperture dimensions if stencil manufacturing process allows for sufficient release at smaller opening.

## IMPORTANT NOTICE

Texas Instruments Incorporated and its subsidiaries (TI) reserve the right to make corrections, enhancements, improvements and other changes to its semiconductor products and services per JESD46, latest issue, and to discontinue any product or service per JESD48, latest issue. Buyers should obtain the latest relevant information before placing orders and should verify that such information is current and complete. All semiconductor products (also referred to herein as "components") are sold subject to TI's terms and conditions of sale supplied at the time of order acknowledgment.

TI warrants performance of its components to the specifications applicable at the time of sale, in accordance with the warranty in TI's terms and conditions of sale of semiconductor products. Testing and other quality control techniques are used to the extent TI deems necessary to support this warranty. Except where mandated by applicable law, testing of all parameters of each component is not necessarily performed.

TI assumes no liability for applications assistance or the design of Buyers' products. Buyers are responsible for their products and applications using TI components. To minimize the risks associated with Buyers' products and applications, Buyers should provide adequate design and operating safeguards.

TI does not warrant or represent that any license, either express or implied, is granted under any patent right, copyright, mask work right, or other intellectual property right relating to any combination, machine, or process in which TI components or services are used. Information published by TI regarding third-party products or services does not constitute a license to use such products or services or a warranty or endorsement thereof. Use of such information may require a license from a third party under the patents or other intellectual property of the third party, or a license from TI under the patents or other intellectual property of TI.

Reproduction of significant portions of TI information in TI data books or data sheets is permissible only if reproduction is without alteration and is accompanied by all associated warranties, conditions, limitations, and notices. TI is not responsible or liable for such altered documentation. Information of third parties may be subject to additional restrictions.

Resale of TI components or services with statements different from or beyond the parameters stated by TI for that component or service voids all express and any implied warranties for the associated TI component or service and is an unfair and deceptive business practice. TI is not responsible or liable for any such statements.

Buyer acknowledges and agrees that it is solely responsible for compliance with all legal, regulatory and safety-related requirements concerning its products, and any use of TI components in its applications, notwithstanding any applications-related information or support that may be provided by TI. Buyer represents and agrees that it has all the necessary expertise to create and implement safeguards which anticipate dangerous consequences of failures, monitor failures and their consequences, lessen the likelihood of failures that might cause harm and take appropriate remedial actions. Buyer will fully indemnify TI and its representatives against any damages arising out of the use of any TI components in safety-critical applications.

In some cases, TI components may be promoted specifically to facilitate safety-related applications. With such components, TI's goal is to help enable customers to design and create their own end-product solutions that meet applicable functional safety standards and requirements. Nonetheless, such components are subject to these terms.

No TI components are authorized for use in FDA Class III (or similar life-critical medical equipment) unless authorized officers of the parties have executed a special agreement specifically governing such use.

Only those TI components which TI has specifically designated as military grade or "enhanced plastic" are designed and intended for use in military/aerospace applications or environments. Buyer acknowledges and agrees that any military or aerospace use of TI components which have **not** been so designated is solely at the Buyer's risk, and that Buyer is solely responsible for compliance with all legal and regulatory requirements in connection with such use.

TI has specifically designated certain components as meeting ISO/TS16949 requirements, mainly for automotive use. In any case of use of non-designated products, TI will not be responsible for any failure to meet ISO/TS16949.

### Products

Audio	<a href="http://www.ti.com/audio">www.ti.com/audio</a>
Amplifiers	<a href="http://amplifier.ti.com">amplifier.ti.com</a>
Data Converters	<a href="http://dataconverter.ti.com">dataconverter.ti.com</a>
DLP® Products	<a href="http://www.dlp.com">www.dlp.com</a>
DSP	<a href="http://dsp.ti.com">dsp.ti.com</a>
Clocks and Timers	<a href="http://www.ti.com/clocks">www.ti.com/clocks</a>
Interface	<a href="http://interface.ti.com">interface.ti.com</a>
Logic	<a href="http://logic.ti.com">logic.ti.com</a>
Power Mgmt	<a href="http://power.ti.com">power.ti.com</a>
Microcontrollers	<a href="http://microcontroller.ti.com">microcontroller.ti.com</a>
RFID	<a href="http://www.ti-rfid.com">www.ti-rfid.com</a>
OMAP Applications Processors	<a href="http://www.ti.com/omap">www.ti.com/omap</a>
Wireless Connectivity	<a href="http://www.ti.com/wirelessconnectivity">www.ti.com/wirelessconnectivity</a>

### Applications

Automotive and Transportation	<a href="http://www.ti.com/automotive">www.ti.com/automotive</a>
Communications and Telecom	<a href="http://www.ti.com/communications">www.ti.com/communications</a>
Computers and Peripherals	<a href="http://www.ti.com/computers">www.ti.com/computers</a>
Consumer Electronics	<a href="http://www.ti.com/consumer-apps">www.ti.com/consumer-apps</a>
Energy and Lighting	<a href="http://www.ti.com/energy">www.ti.com/energy</a>
Industrial	<a href="http://www.ti.com/industrial">www.ti.com/industrial</a>
Medical	<a href="http://www.ti.com/medical">www.ti.com/medical</a>
Security	<a href="http://www.ti.com/security">www.ti.com/security</a>
Space, Avionics and Defense	<a href="http://www.ti.com/space-avionics-defense">www.ti.com/space-avionics-defense</a>
Video and Imaging	<a href="http://www.ti.com/video">www.ti.com/video</a>

### TI E2E Community

[e2e.ti.com](http://e2e.ti.com)